

# Learning Islam for Infants



SAMPLE WORKSHEETS



4-7 years





# Preface

---

This book contains a sample of photocopiable worksheets to help you to teach the eleven strategies in the Q School Learning Wheels for Infants (Upto 7 years)  
For more learning resources visit [www.qfatima.com](http://www.qfatima.com).



# Asmaul Husna

Fill in the missing names of Allah in the boxes



# Al - Aleemu

## The One Who Knows Everything

---

Write or draw in the boxes what else you can do to increase your knowledge.

### Learning how to make one healthy

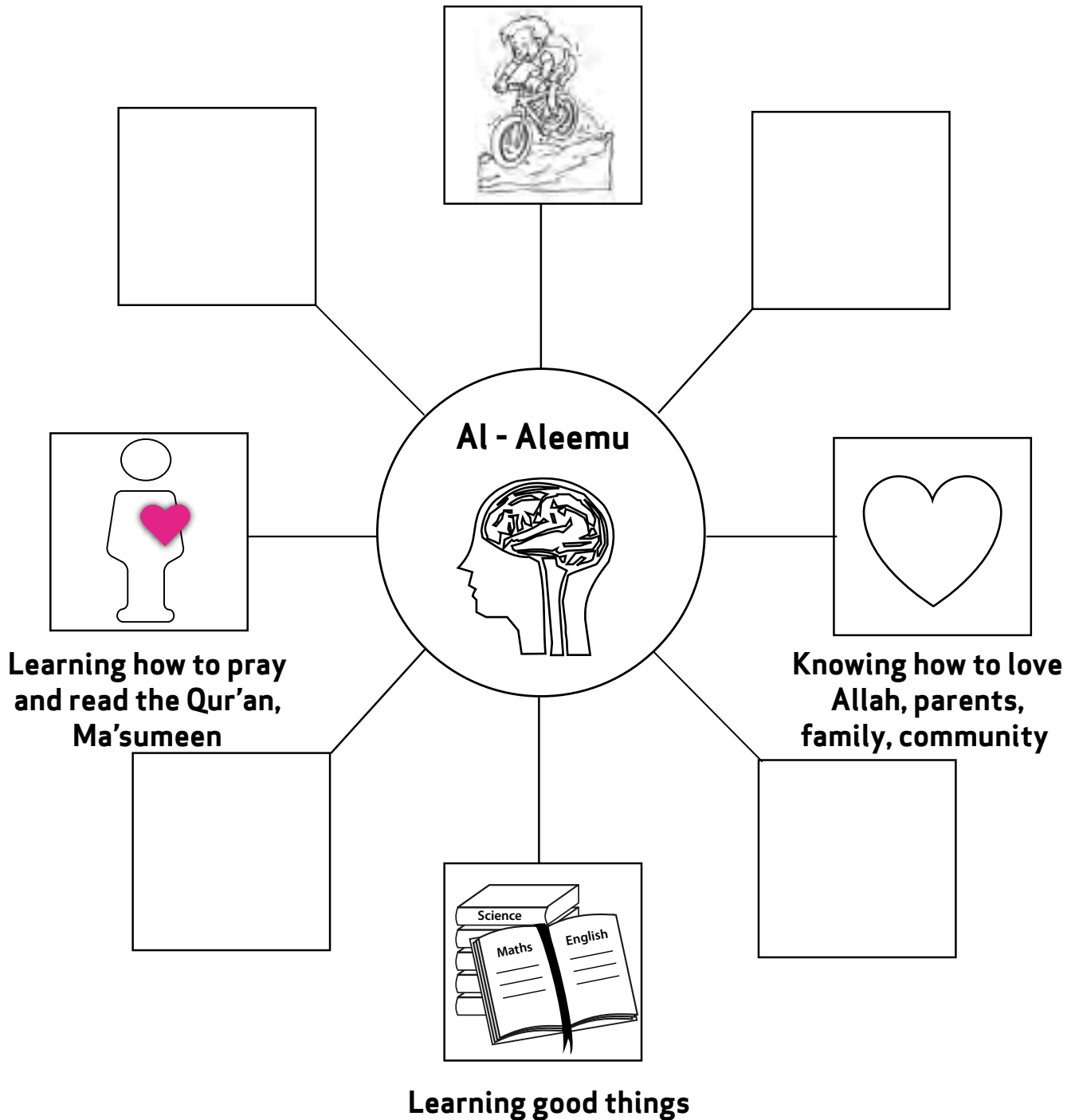

# Al - Baseeru

## The One Who Sees Everything

---

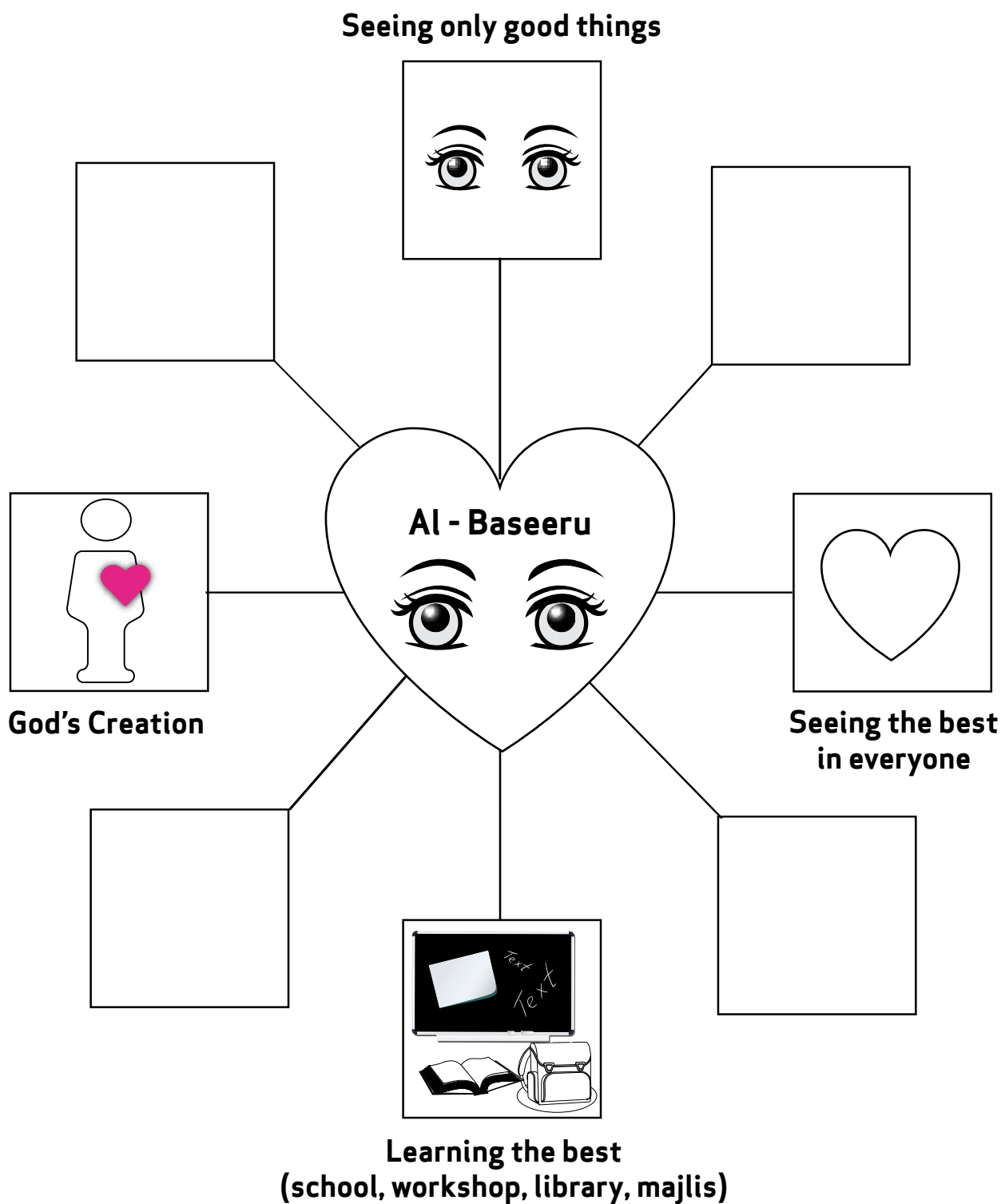

Write or draw in the box what else you can see that is good?





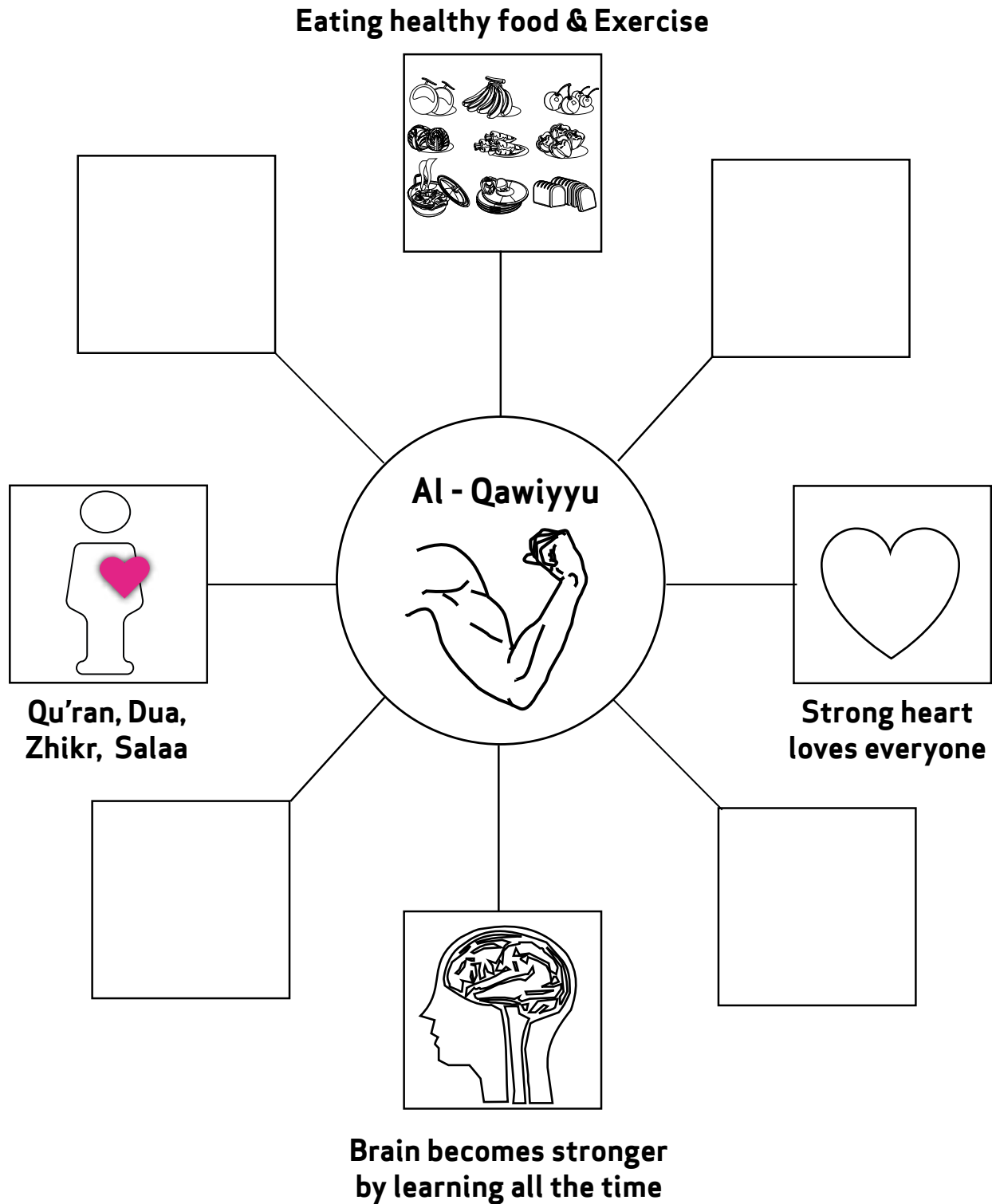

# Al - Qawiyyu The Strong

Write or draw in the boxes what else you can do to be strong.



# Al Aziz – The Mighty

“ IZZ ” means might , power , strength and victory. In order to be victorious we have to undergo a process in order to overcome our weaknesses and be successful. Try and complete the table below. Some have been done for you.

	WEAKNESSES	PROCESS TO UNDERGO	VICTORIOUS
 <b>typical student</b>	Chats a lot on the computer.		 A Graduate
 A basketball player	Eat a lot of junk food.		 Winner
<b>A CARELESS MUSLIM</b> - who does not pray on time, is naughty at times, bullies others, tells lies and also up sets his parents		Try to keep an alarm clock	To be able to pray to Allah with a clean heart and be His obedient servant.   <b>Muslim Prayer</b>





# Al - Malik - The King

Below is a table where certain things belong to certain people, they own it and have control over it. All the things have been jumbled up.

ACTIVITY:

Colour all things belonging to the cook RED, to the barber BLUE, to the handy man GREEN, to the artist YELLOW and to the farmer BROWN.

Who do you think is the owner of everybody , everything, every soul and the entire Universe?

WHO IS THE KING OF ALL KINGS ??????

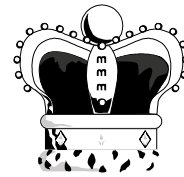

Cook	Barber	Handy Man	Artist	Farmer
Scissors	Spaner	Turpentine	Spade	Pans
Hammer	Flour	Screw driver	Canvas	Mirror
Easle	Combined Harvester	Soil	Oven	Fertilizers
Washing up liquid	Oil paints	Trimmer	Saw	Pencils
Seeds	Hair dryer	Spices	Gel	Drill



# Al - Quddoos

## Pure and free from all faults

---

Below are 2 pictures. The one on the left is the perfect picture as there are no mistakes in it. There are 10 mistakes in the picture on the right. Can you spot them? Circle the 10 differences.



# Al - Quddoos

## Pure and free from all faults

---

In your opinion what are / is .....



A Perfect Friend

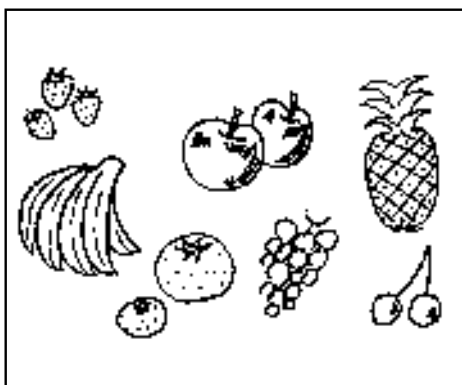

A Perfect Fruit



A Perfect World

Allah is pure and perfect ( Al Qudoos ) because He is ...



# As - Sameeu

## The One Who Hears Everything

Write or draw in the boxes what other good things you can hear.

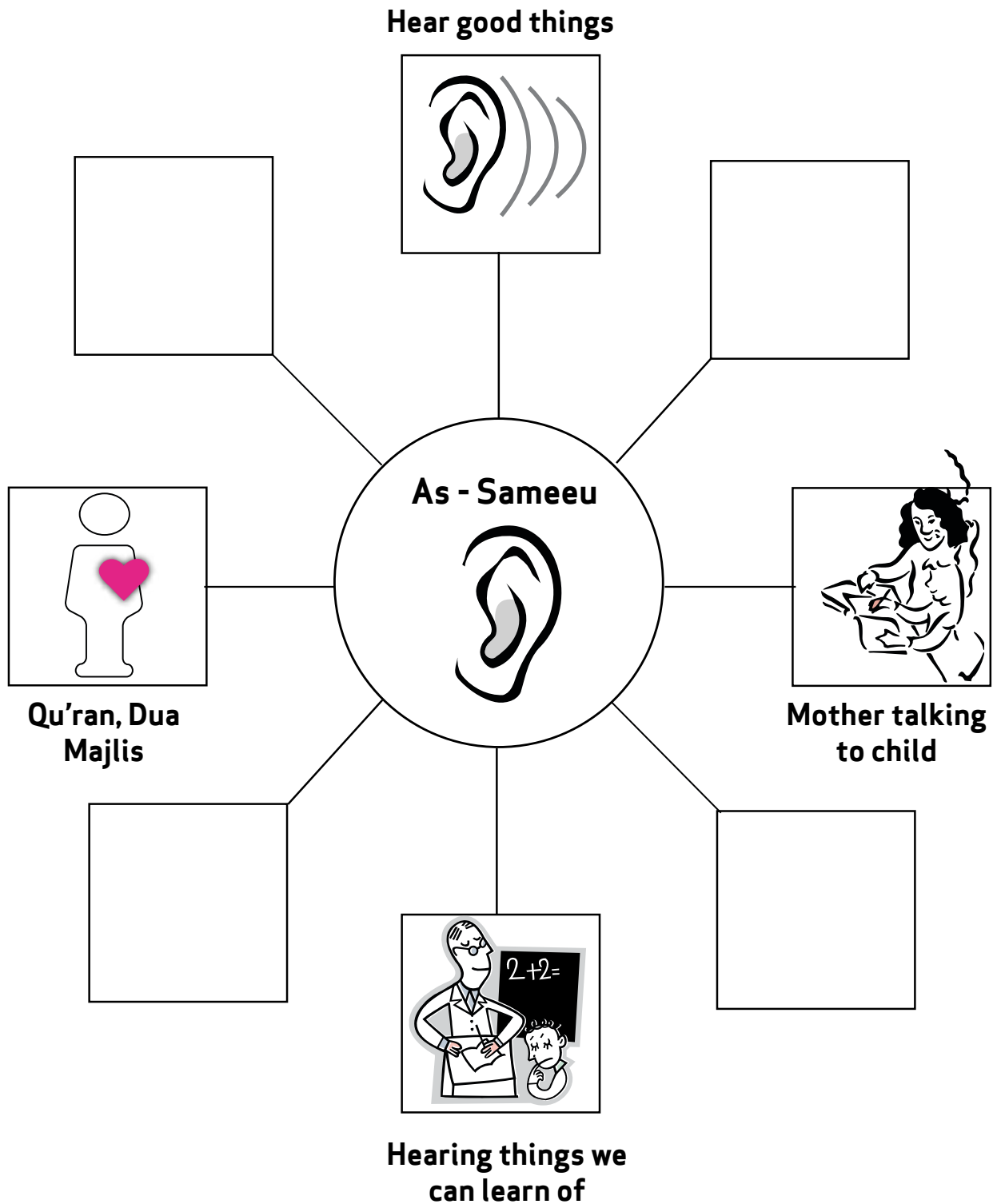

# Ash - Shaafi

## The One Who Makes Better

---

Write or draw in the box things that make you better

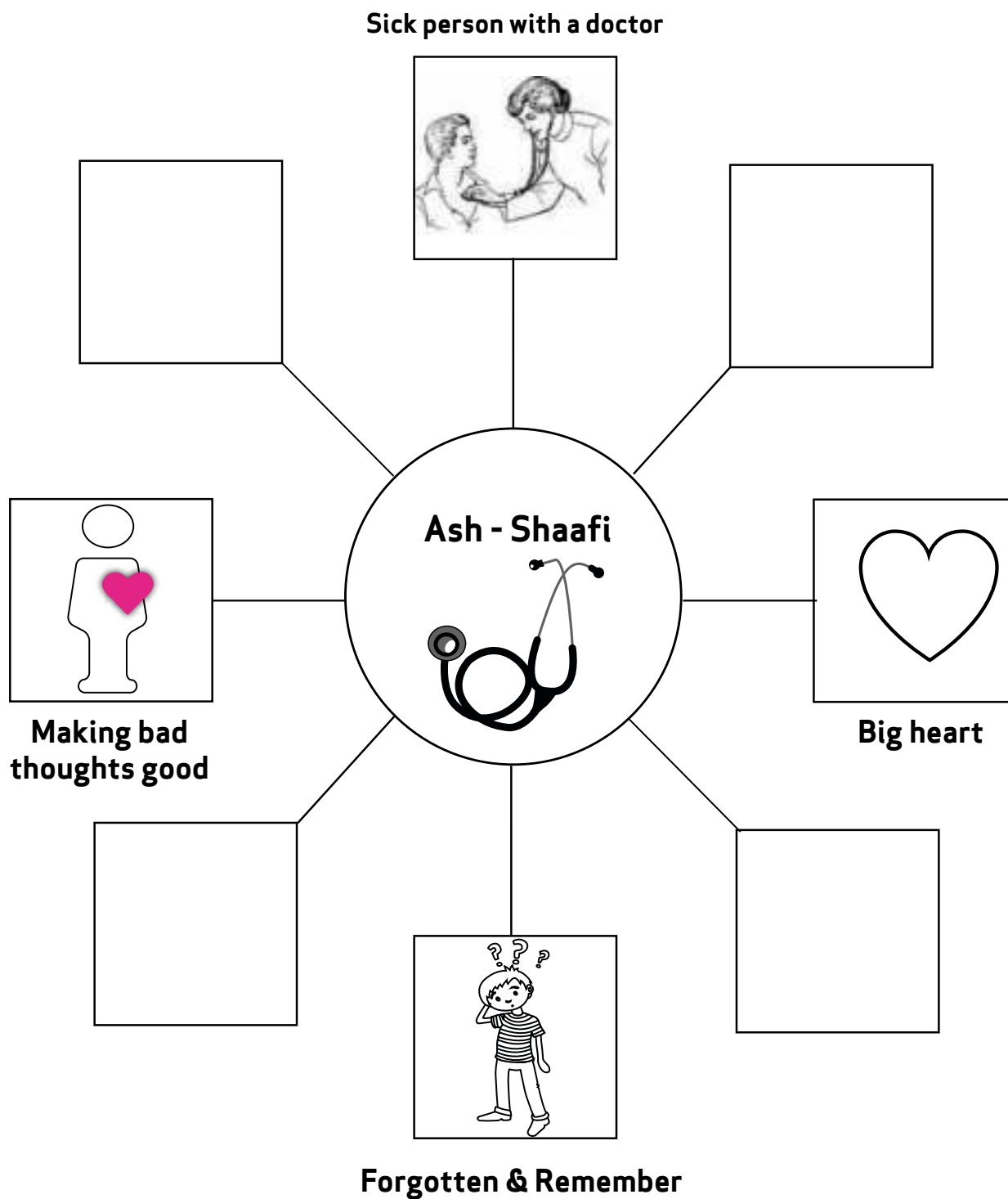

# The All - Seeing

---

Allah sees everything we do. Draw or write what Allah would like to see you doing?

Draw or write some of the things Allah would not like to see you doing?

Example



Cheating in a test



# Activity Sheet (Kalima)

Match the columns below:

رَسُولُ اللَّهِ

لَا إِلَهَ

إِلَّا اللَّهُ

عَلَيَّ

وَلِيُّ اللَّهِ

مُحَمَّدٌ

بِلاَ فَصْلٍ

وَمَهِيَّ

رَسُولُ اللَّهِ

وَخَلِيفَتُهُ



# Usul E Deen

---

What are the 5 usul of deen? (roots of religion)

Put one in each balloon choosing the right answer from the list below:

Nabuwwa, Salaa, Adala, Tawheed, Imama Hajj, Qiyama, Zaka, Jihad

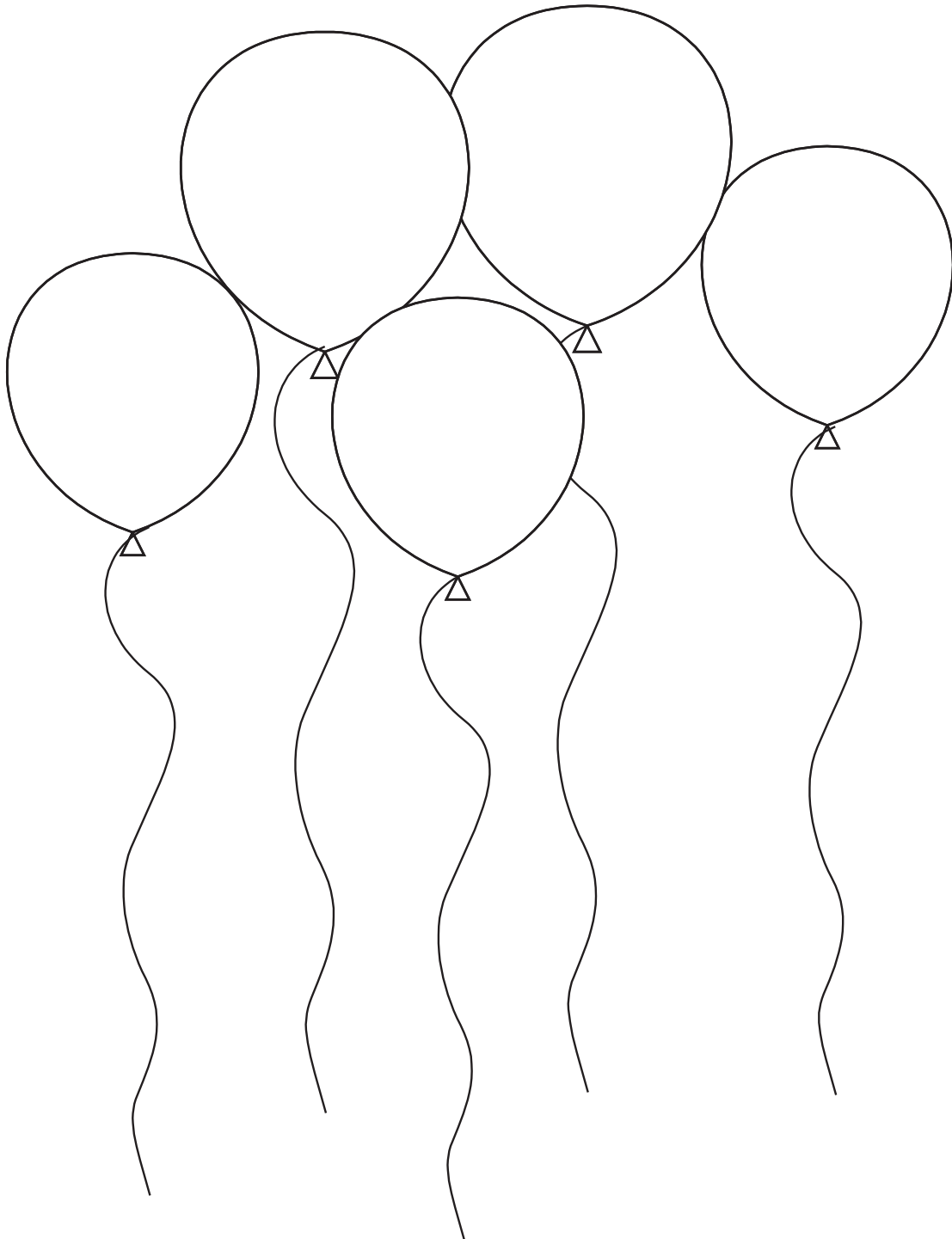



# I cannot see Allah with my eyes...

Whose footprints made the guest of the farmer believe in Allah?  
Draw in the animal in the circle below!

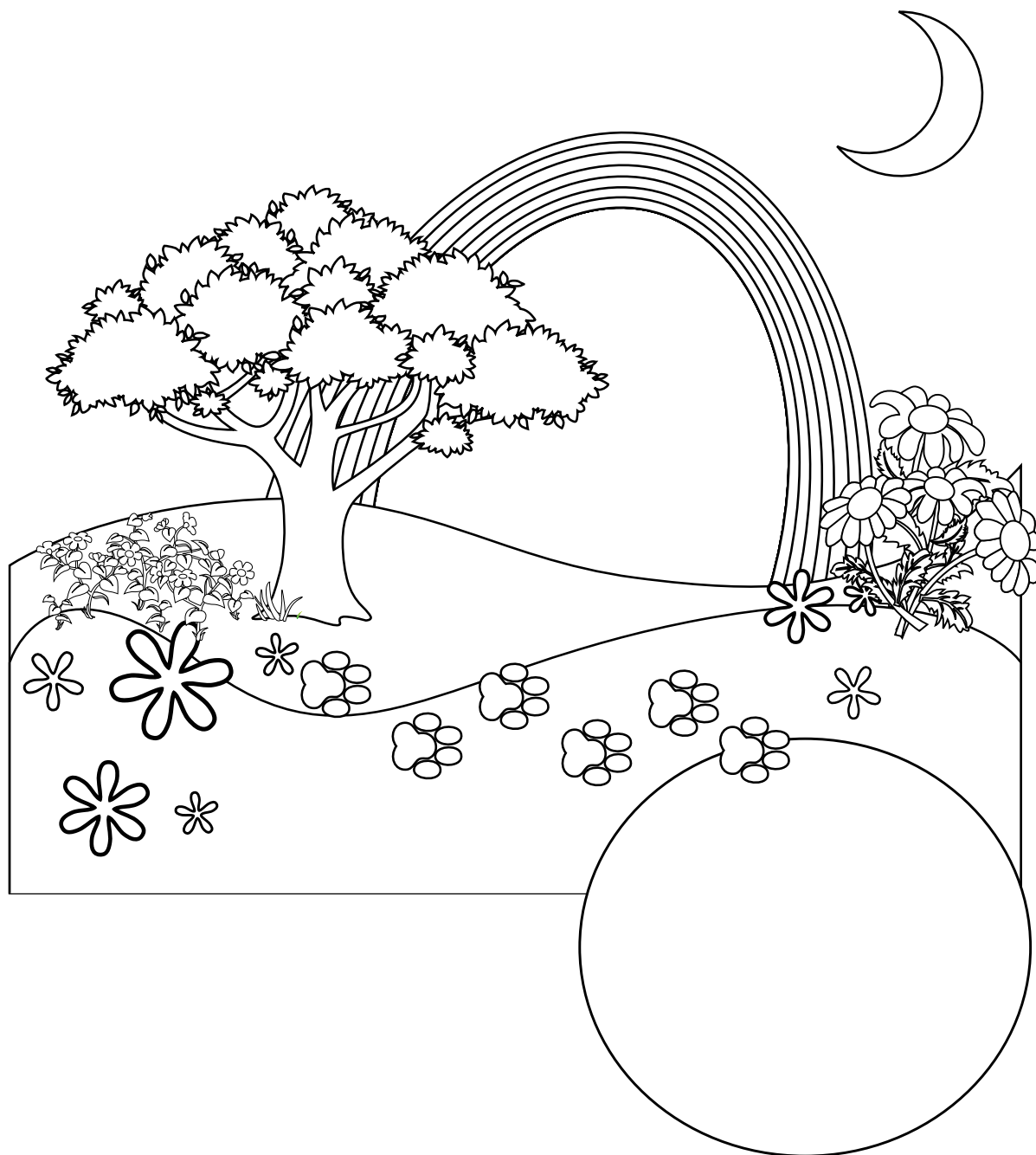

# Love of Allah

---

**Allah is the proprietor and the human being a lease holder.**

## **LOVE OF ALLAH**

Love of Allah has to be shown through our actions and akhlaq.

Think of an invisible chain that binds you to Allah.

Cut out strips of sugar paper and make a chain writing on each one that brings you closer to Allah and demonstrates your love for Allah.

Here are a few to start you off....

Obedience, truthfulness, niyya, farness from sins, knowledge, good akhlaq.....

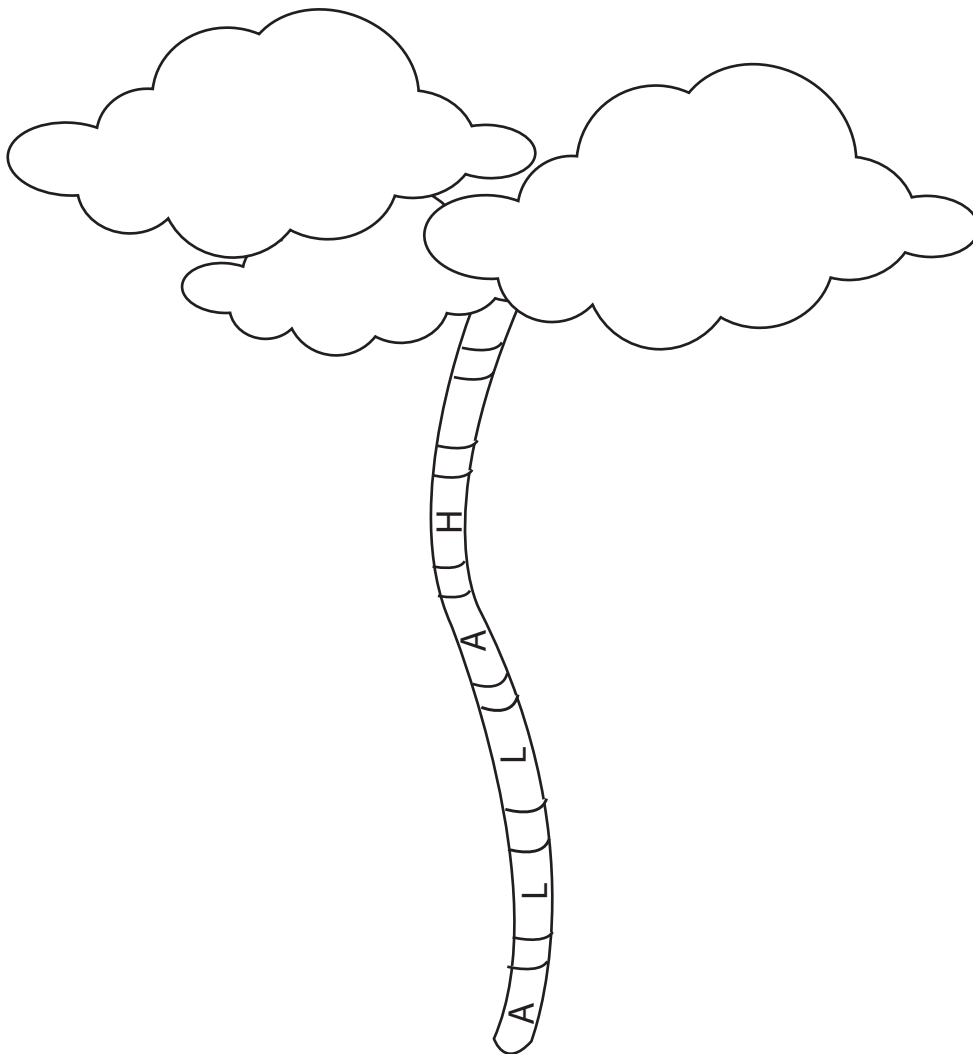

# Lillah

---

When we do anything for Allah; the jaza (reward) is given both in this world and in the hereafter.

Colour the rewards of this world in green and the rewards of the hereafter in yellow.

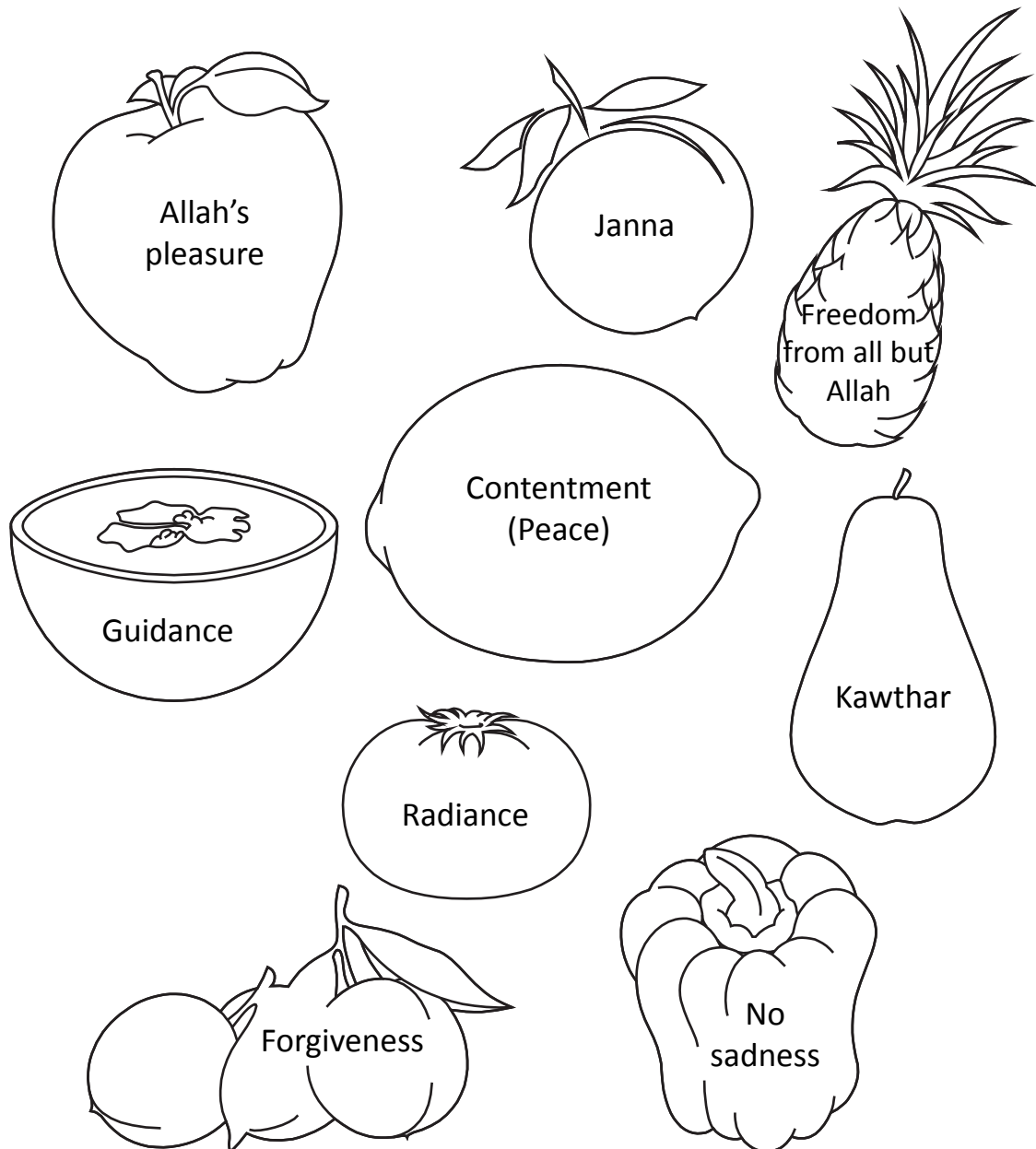

# Who Am I?

Creations of Allah:

<b>ELEPHANTS</b>	<b>FLOWERS</b>	<b>WHALES/ FISHES</b>	<b>FROGS</b>
<b>TREES</b>	<b>LIONS</b>	<b>SUN</b>	<b>HUMAN BEING</b>
<b>ANTS</b>	<b>STARS</b>	<b>WORMS</b>	<b>SNAKES</b>

Above are some of Allah’s creations, from them pick out any three creations of your choice and write them in the table below, also write down three things that each creation can do. One has been done for you.

<b>HUMAN BEING</b>			
<b>He can think</b>			

From your table above see which one is the best creation and write it down, also tell us why it is the best.

I think the best creation is .....

because it .....

.....

**“Certainly We created man in the best make” Suratul Teen: 4**



# Subhanallah (Glory be to Allah)

---

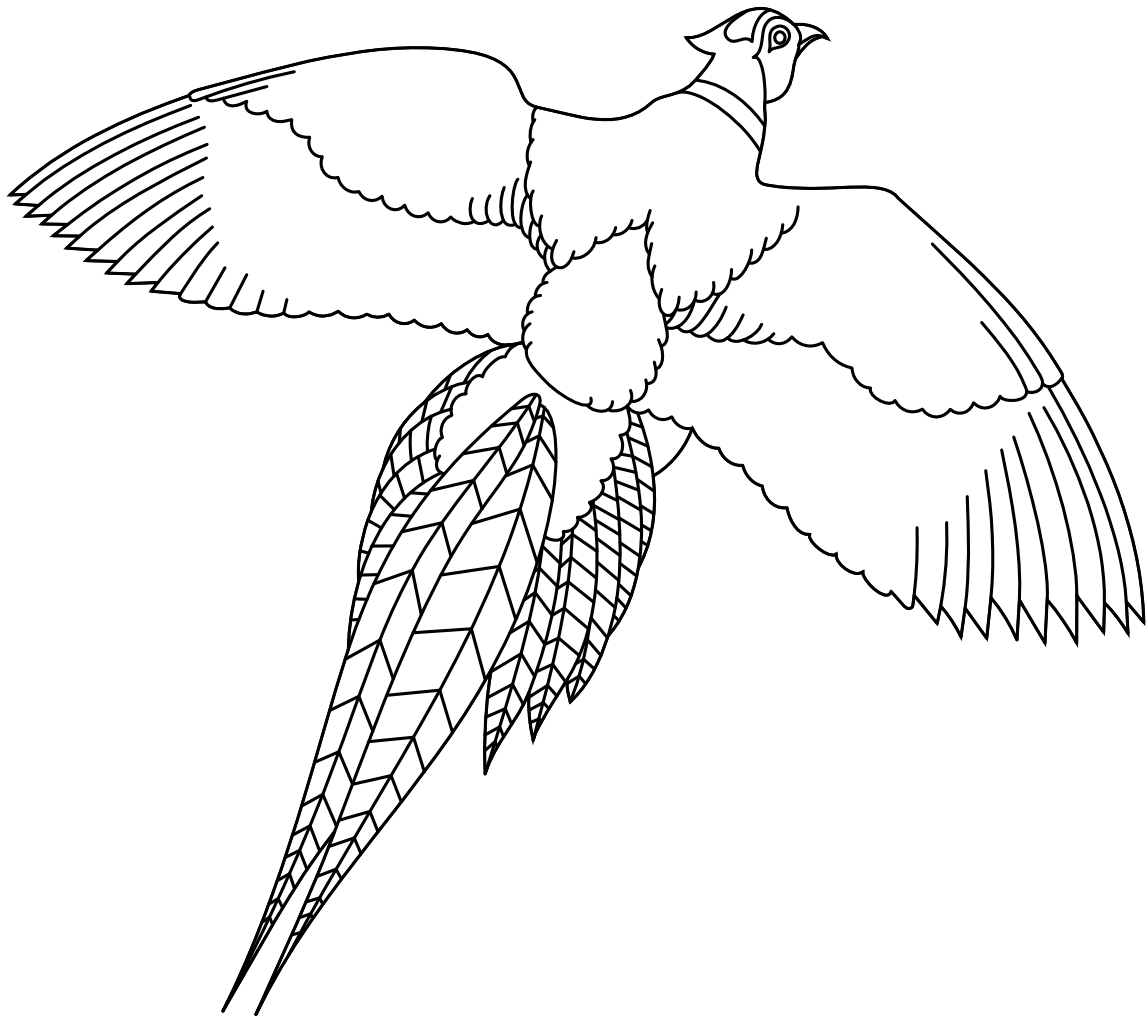
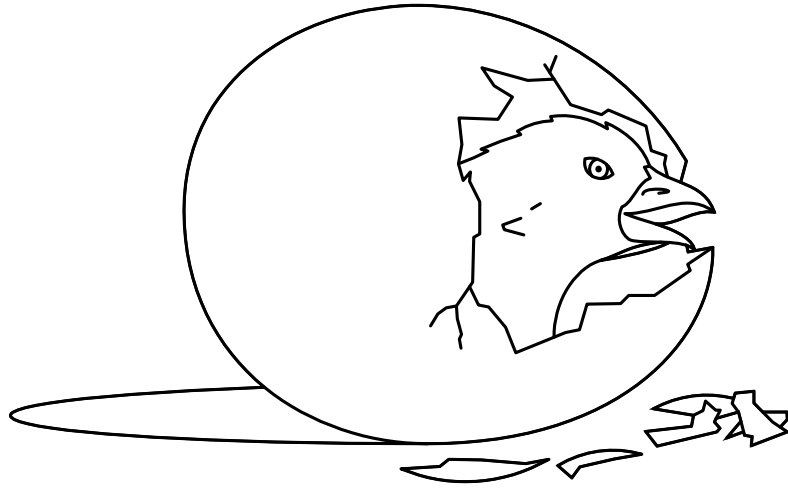

# Subhanallah (Glory be to Allah)

---

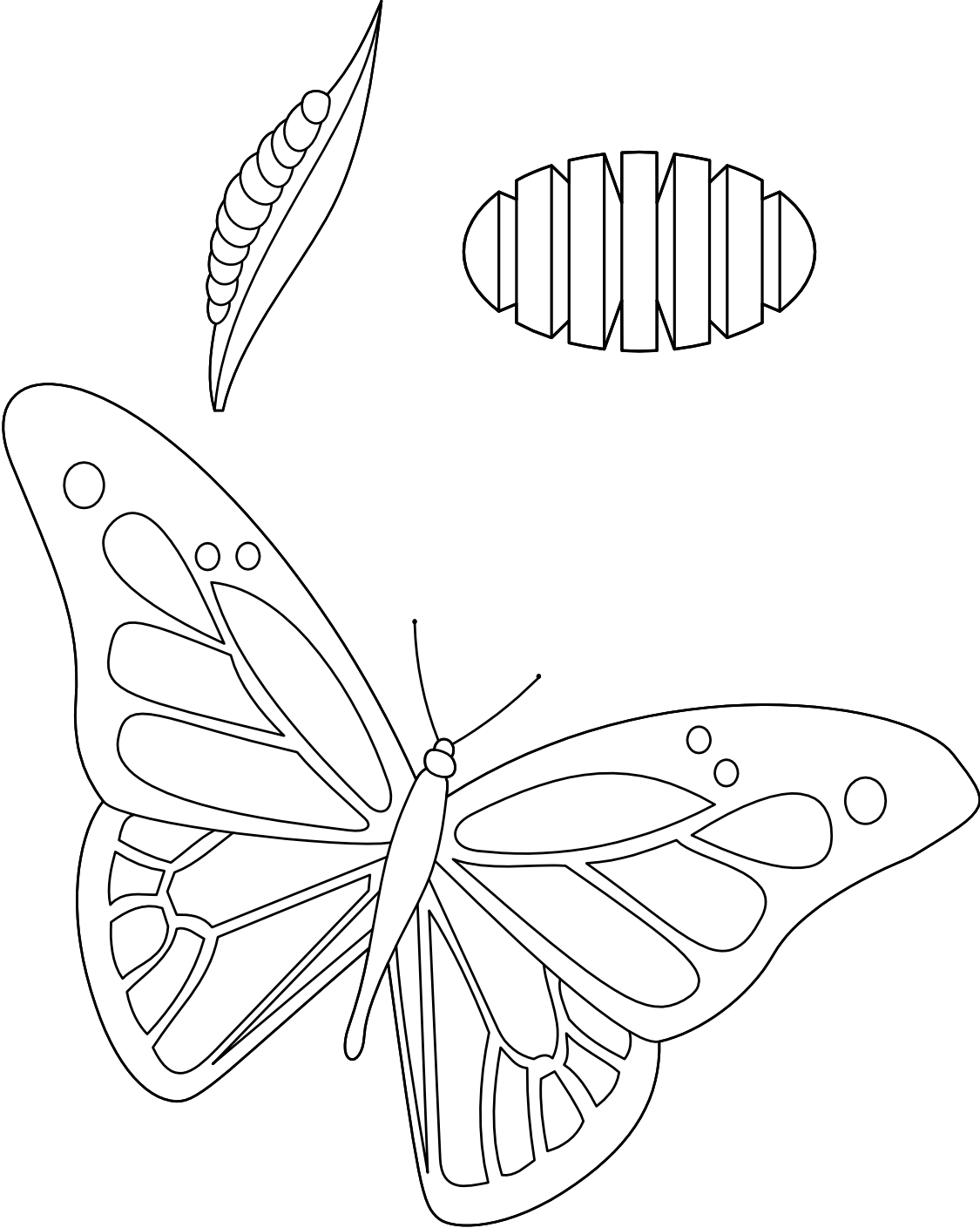

# Usul & Furu

Draw symbols for each of the usul & furu

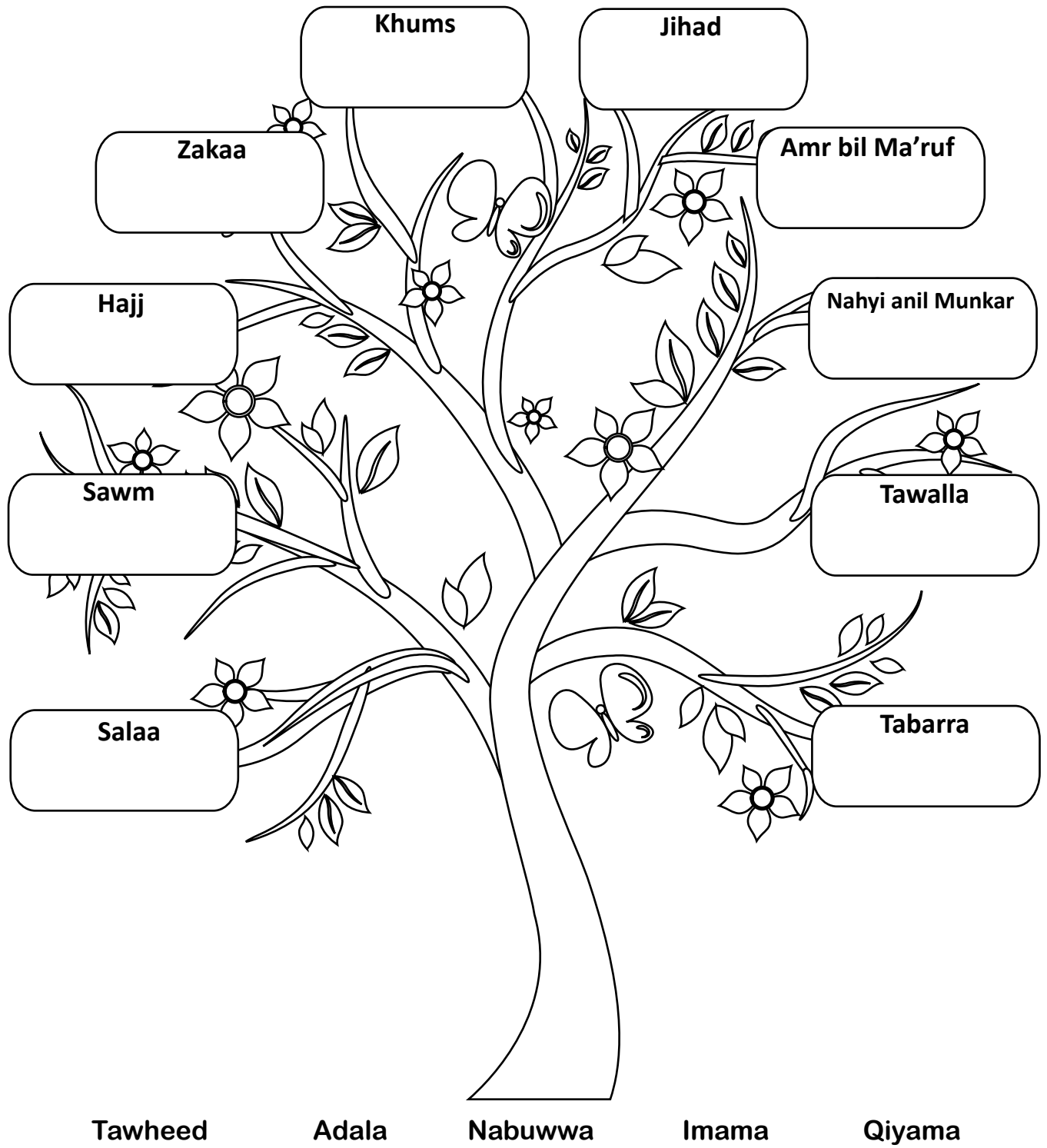

# Going to Janna...

---

Ruqayya is packing to go to Janna.  
Circle what she needs to have in her case.

Kalima

Naughty deeds

Lots of thawaab

Salaa

Kafan

Reciting Qur'an

Good Akhlaq

Listening to mummy

Shorts & T Shirt

Sunglasses

Fasting

Hajj

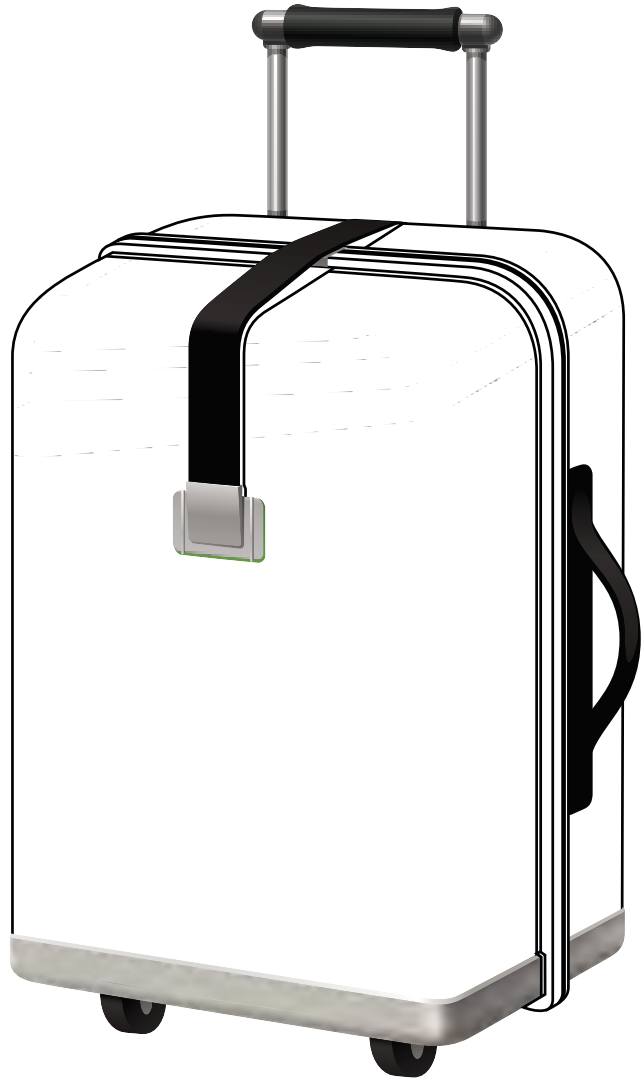



# Steady Feet

---

**“O you who believe! If you help the cause of Allah,  
He will help you and make our feet firm!”  
Qur’an - Suratu Muhammad 47:7**

One of the roads leads to Janna and the other to Jahannam.  
Which will you take?

Your feet must be very steady. Cut out the feet shapes from below and stick them on the road you want to go on!!!

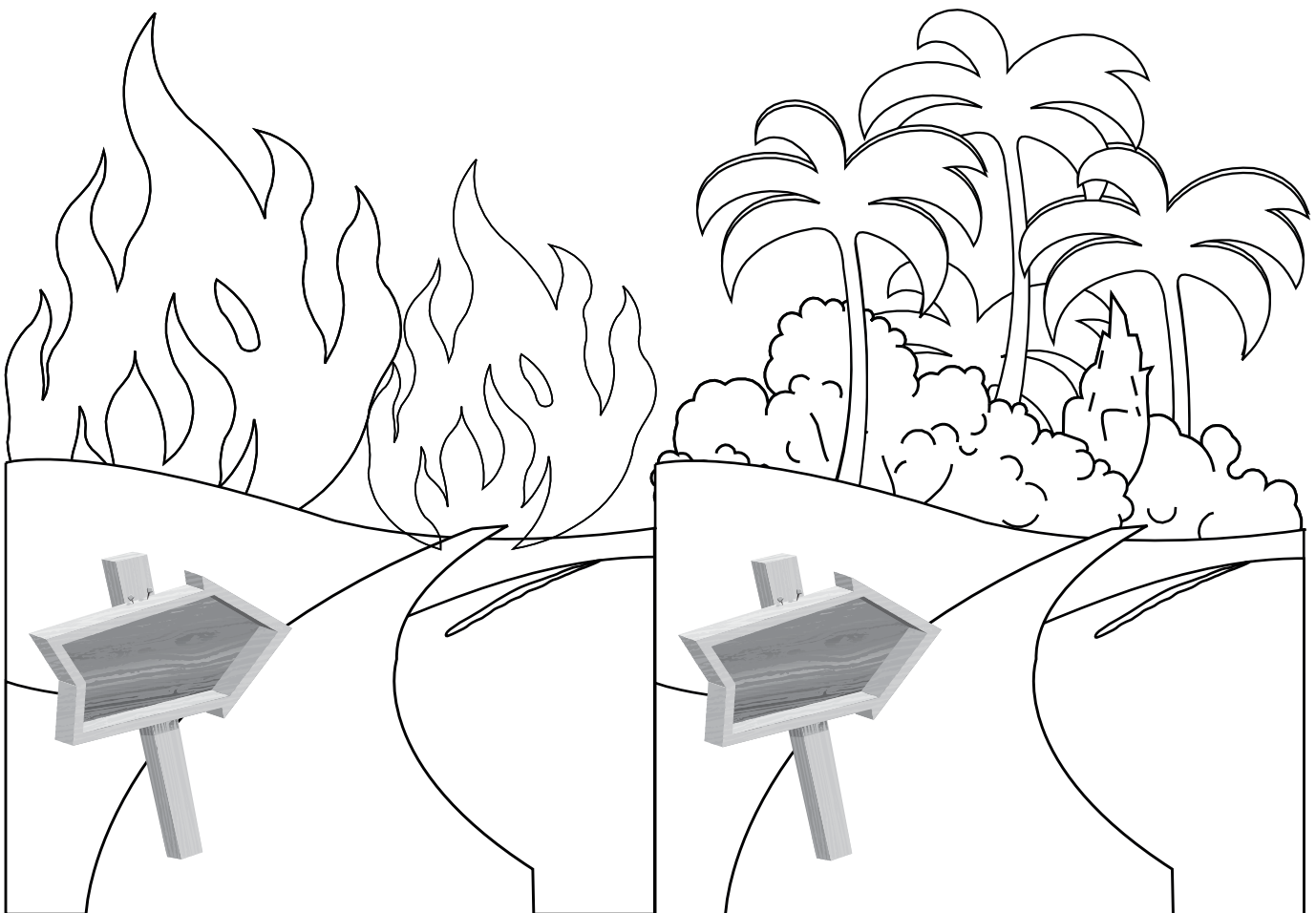

# Prophets

---

Match the columns below:

**Prophet Muhammad  
(pbuh)**

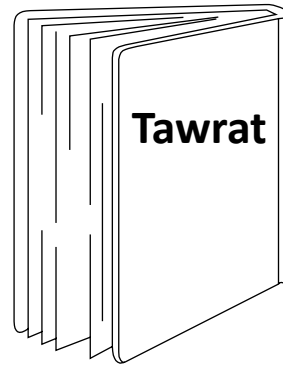

**Prophet Isa (pbuh)**

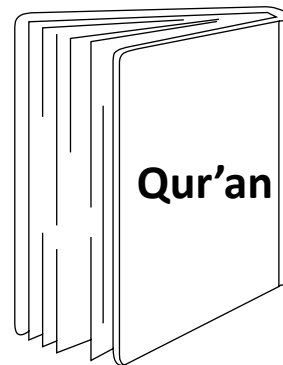

**Prophet Dawud (pbuh)**

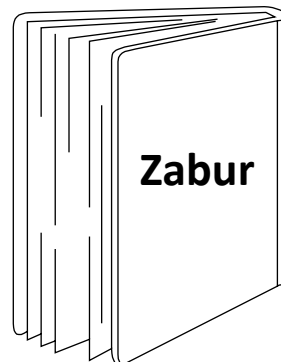

**Prophet Musa (pbuh)**

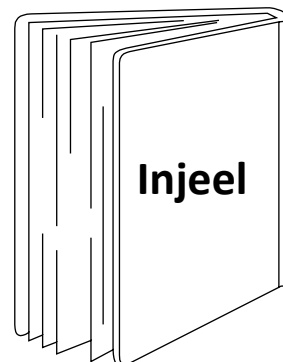

# Angels

---

Colour and fill in the names of the four special angels and write below of what they do:

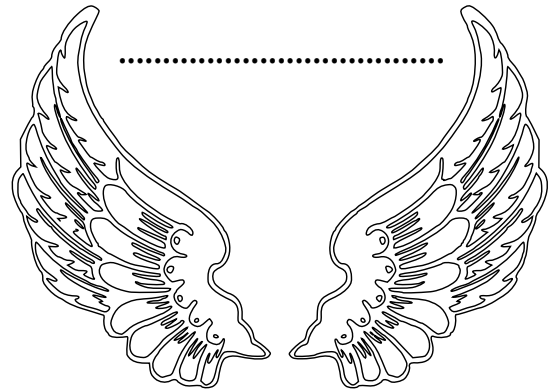
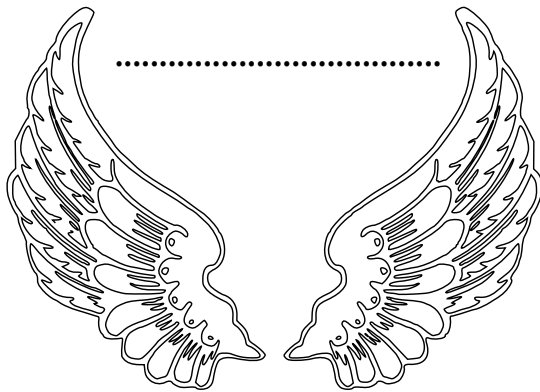

.....

.....

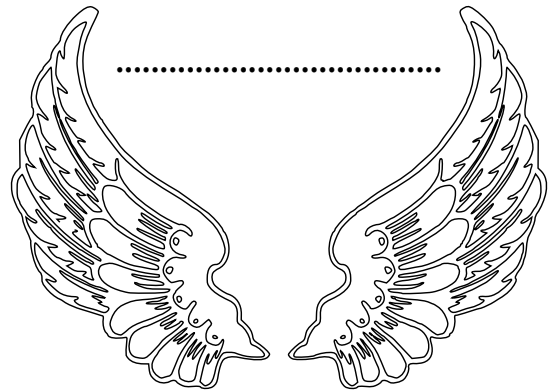
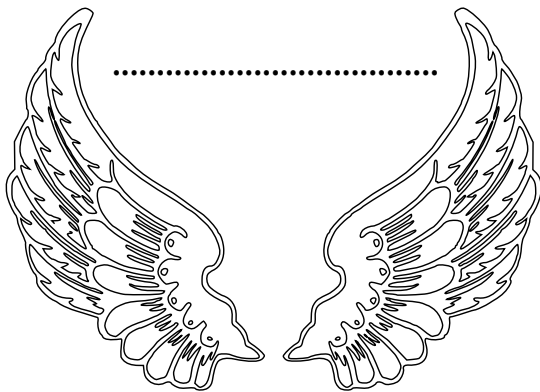

.....

.....



# Fiqh Terms

Colour the cars in the colours of the traffic light to which they belong.

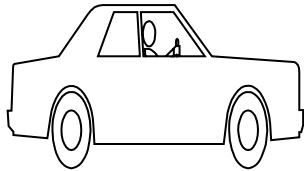

**Salaa**

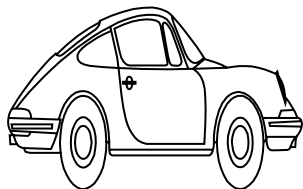

**Helping mummy**

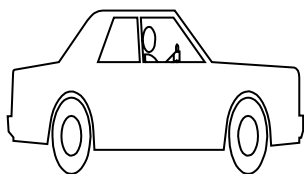

**Lying**

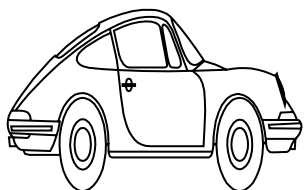

**Swearing**

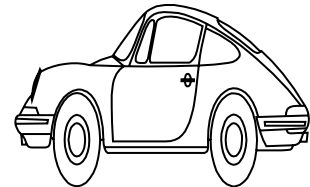
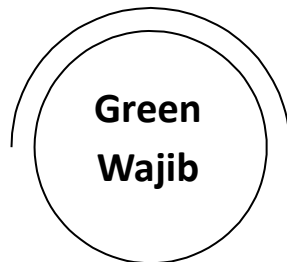
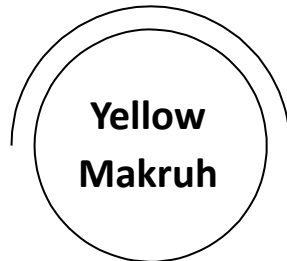
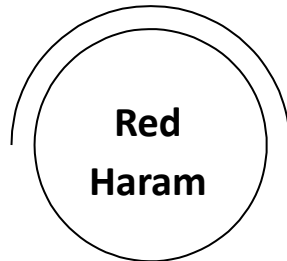

**Reciting Qur'an**

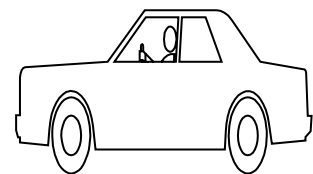

**Ghisl of Jumua'**

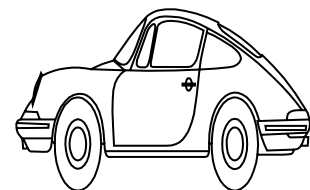

**Obeying Allah**

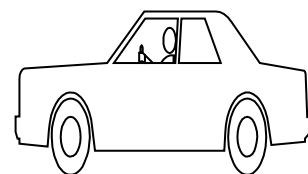

**Talking on the toilet**



# Fiqh Terminology

Unscramble the following and put them in the correct blanks.

J I A W B \_ \_ \_ \_ \_      H M A R U K \_ \_ \_ \_ \_

R H M A A \_ \_ \_ \_ \_      S H A T U M A B \_ \_ \_ \_ \_

1. Acts that we MUST DO are called \_\_\_\_\_
2. Acts that are BETTER NOT TO DO are \_\_\_\_\_
3. Acts that we MUST NOT DO are called \_\_\_\_\_
4. Acts that ar GOOD TO DO are called \_\_\_\_\_

Mark each box with the recommended act

SALAA	GO TO MOSQUE	DO GHUSL JUMMAH	WEAR BLACK SHOES
TO SLEEP AFTER SUBH SALAA	TO CUT YOUR NAILS ON FRIDAY	TO LIE ABOUT YOUR BEST FRIEND	READ TASBEH & DUA AFTER SALAA
TO BACKBITE ABOUT OTHERS	SAUM	BRUSH TEETH BEFORE SALAA	GO FOR JUMMAH SALAA
START MY FOOD WITH A PINCH OF SALT	TO COVER MY HEAD WHEN I AM IN THE TOILET	LISTEN TO MUSIC	DRINK WATER WHILST STANDING AT NIGHT
TO GIVE AWAY 1/5 OF MY ANNUAL SAVINGS	TO DO GOOD & ASK OTHERS TO DO GOOD	STEAL	TO KNOW ABOUT MY PRESENT IMAM



# Tasleem (Submission)

---

Tasleem comes with knowledge.

Draw and / or write the things which are wajib, haram, mustahab, makruh, jaaiz...

<b>Wajib</b>	<b>Haram</b>
<b>Mustahab</b>	<b>Makruh</b>
<b>Jaaiz</b>	



# Taqleed

Match the columns

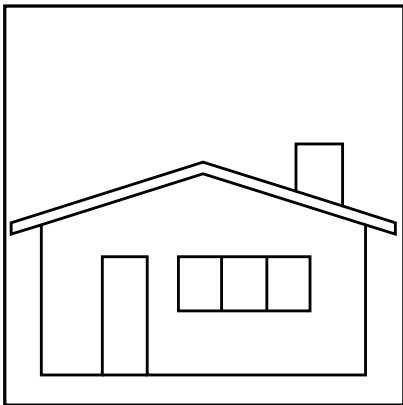
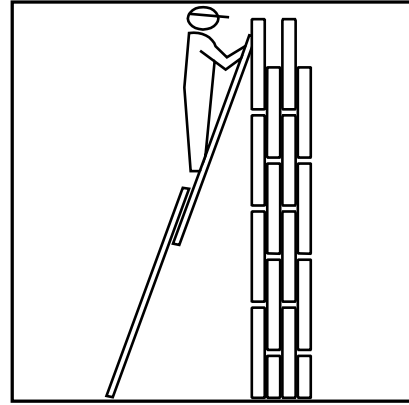
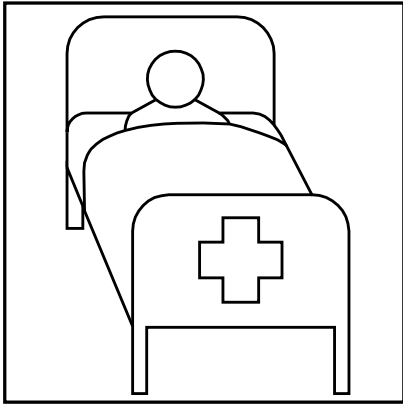

Marja' Taqleed  
most  
learned scholars

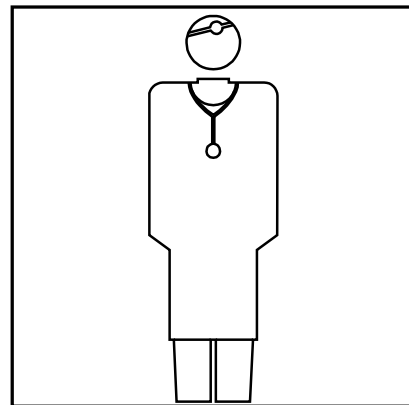
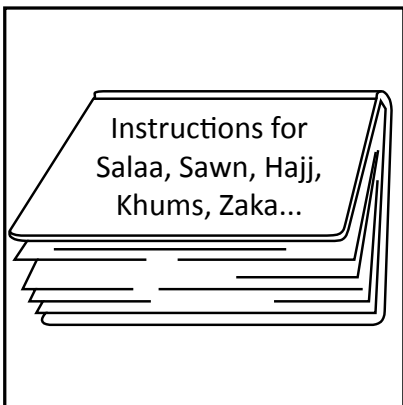

# Najasat

Circle which is najis:

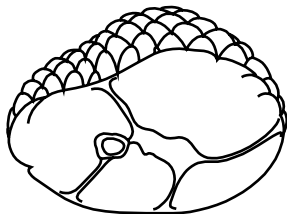
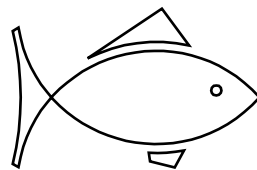
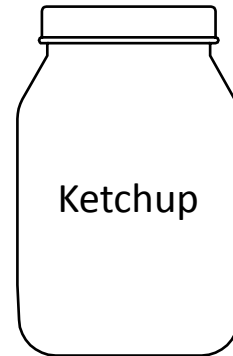
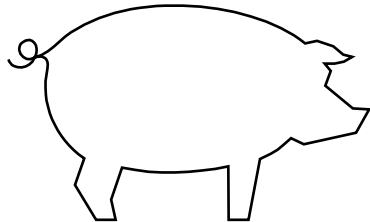

Ham

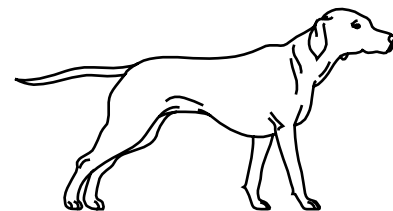
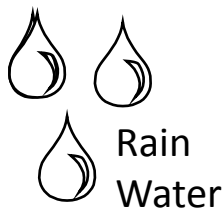

Wee Wee  
and Poo

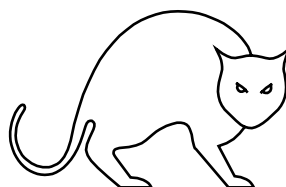
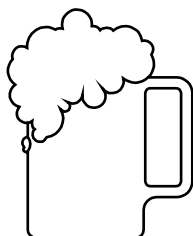
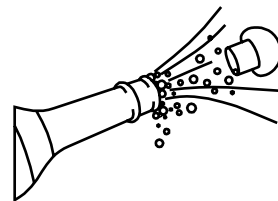
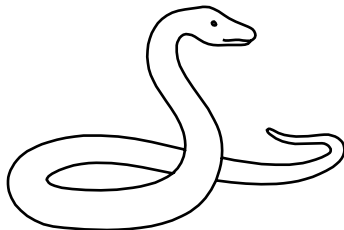



# Intention Niyya

“Intention is superior to action, or rather, intention is the complete reality of act itself” Holy Prophet.

Colour the pictures and write down why each young boy is studying.



I am studying because .....

.....  
.....  
.....  
.....



I am studying because .....

.....  
.....  
.....  
.....



I am studying because .....

.....  
.....  
.....  
.....



# Wudhoo Worksheet

1. Do you know how to perform the Wudhoo correctly?  
(Ask your parents to check your wudhoo for you.)

2. Do the Activity Below:

Taha is trying to do wudhoo but he has all the actions mixed up.

Put numbers in the circles besides each action in order that he can do his wudhoo correctly.

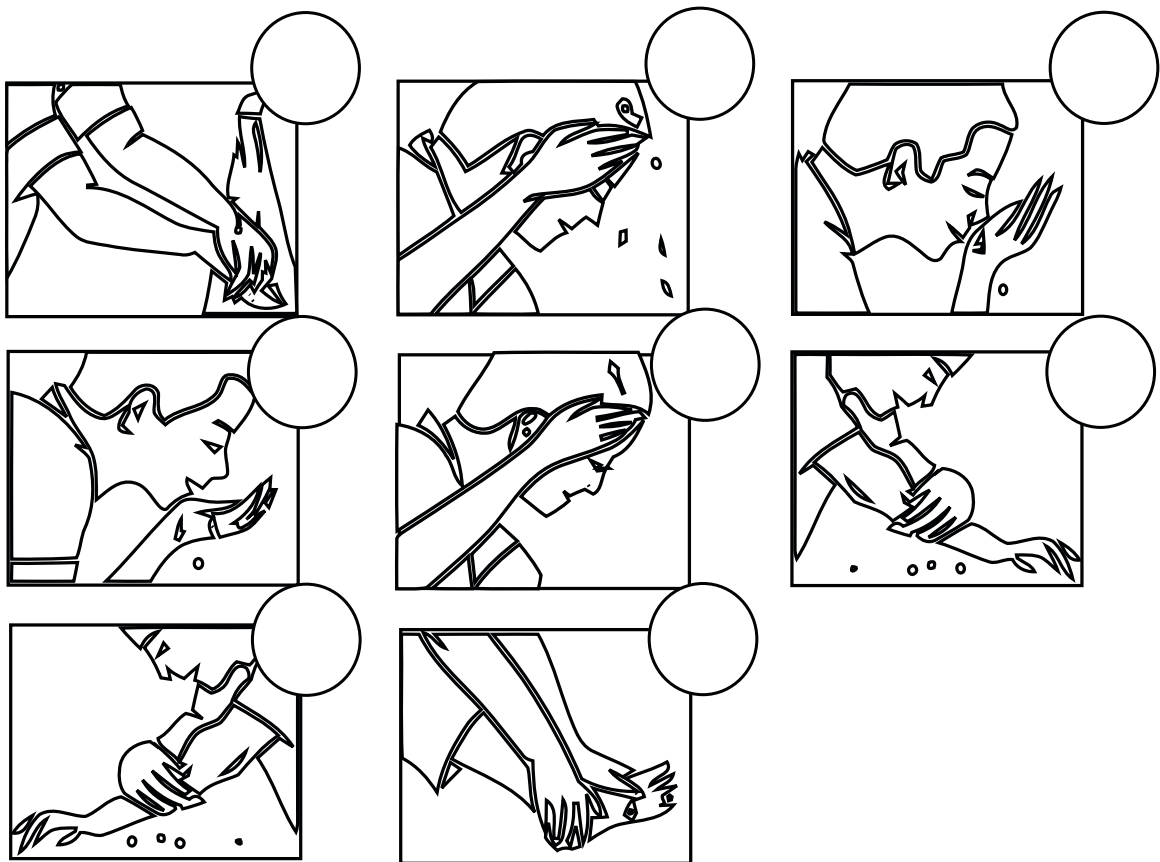

# Adhan

---

Colour the balloons which we should be thinking about when we recite 'Hayya alal falaah'- Hurry to success.

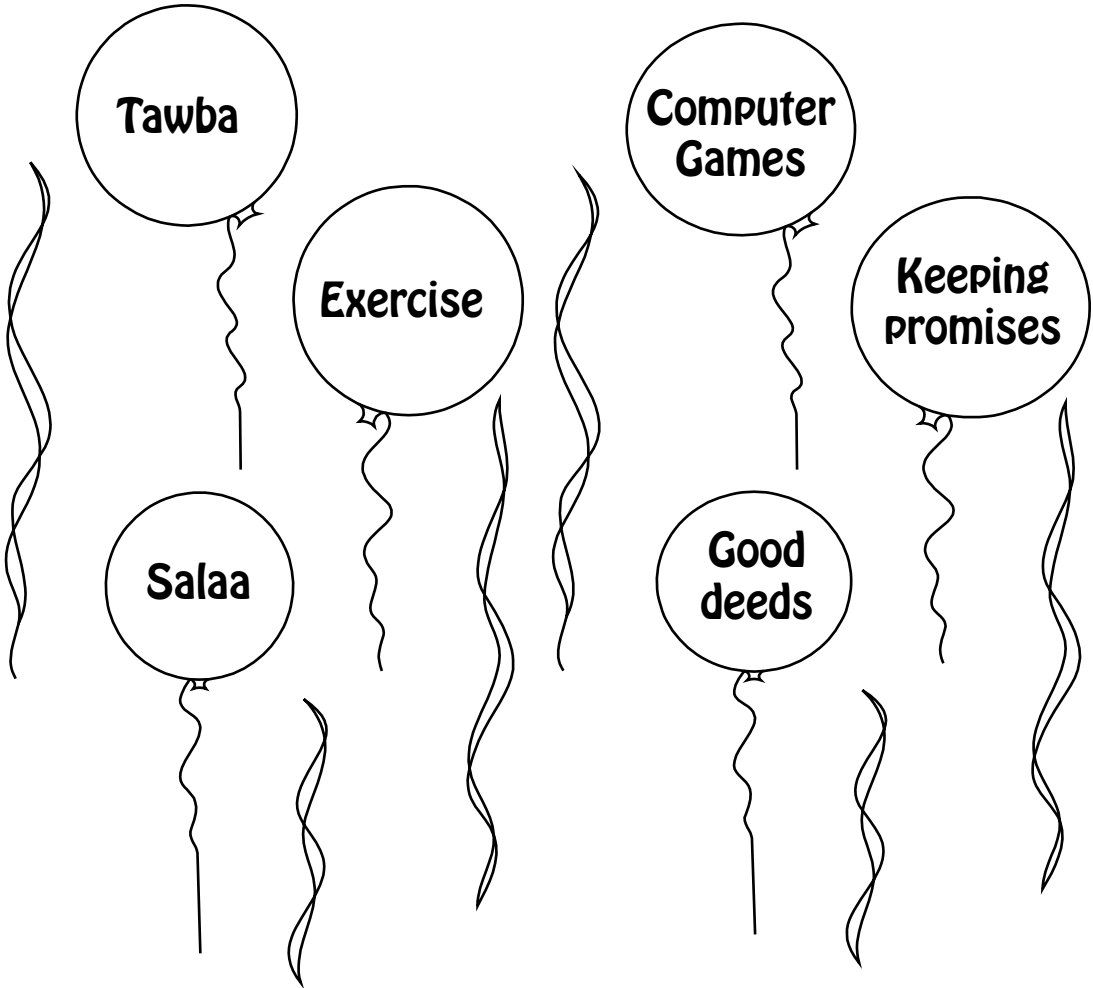

# Al-Ka'batu Qiblaty

The Ka'ba is my qibla

---

Draw things that can show you direction of Qibla

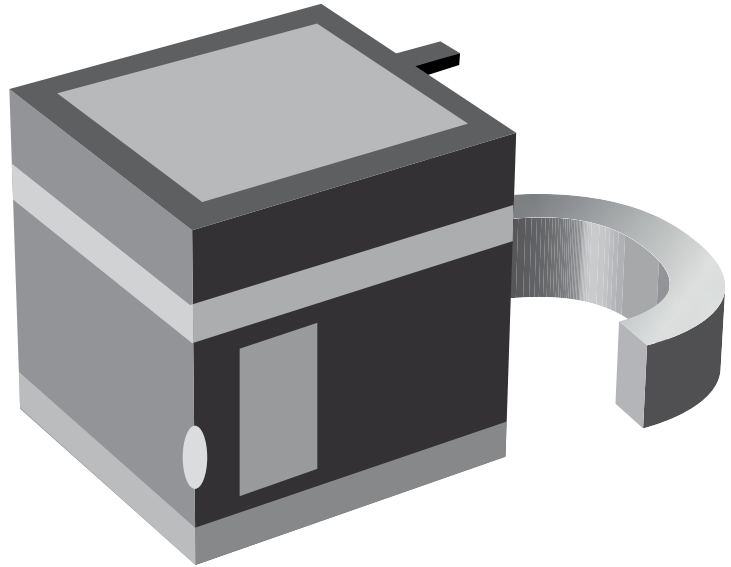

# Salaa

---

Match the columns below:

	No. of Rakats
<b>Maghrib Salaa</b>	<b>4</b>
<b>Asr Salaa</b>	<b>3</b>
<b>Fajr Salaa</b>	<b>4</b>
<b>Isha Salaa</b>	<b>2</b>
<b>Dhuhr Salaa</b>	<b>4</b>



# Place for Salaa

Put a cross on the things that are Makruh to pray Salaa

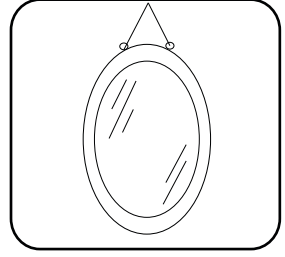
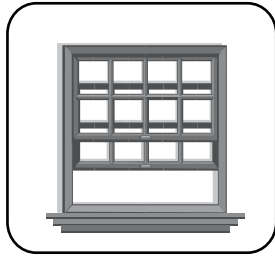
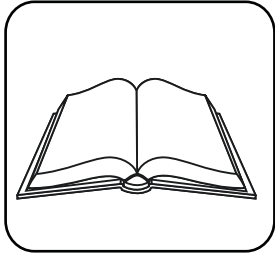
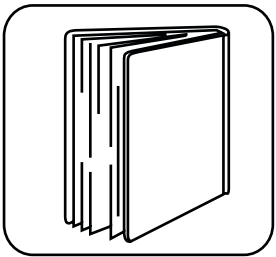
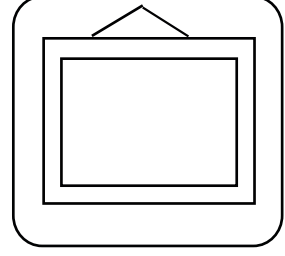
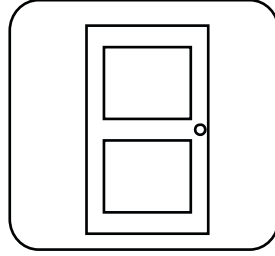
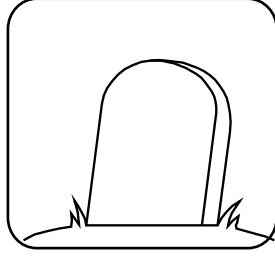
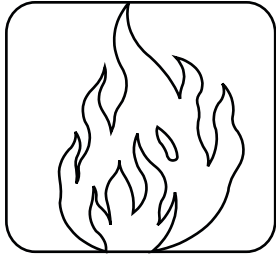

Answer the following questions by colouring the right box.

1. Can you pray in someone's house without asking them?

**Yes**

**No**

2. The thawaab for praying one rakaat salaa in Masjidul Haram? (mosque where Ka'ba is)

**1  
rakaat**

**12  
rakaat**

**100  
rakaat**

**10,000  
rakaat**

**100.000  
rakaat**



# Actions of Salaa

---

Number the actions of salaa in their correct order (tarteeb).

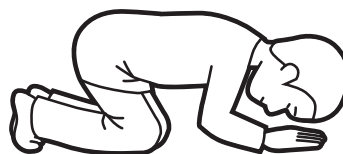
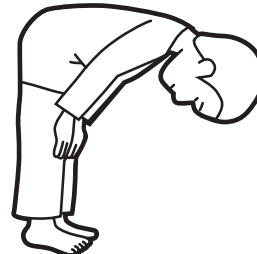
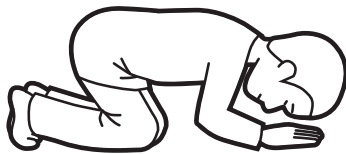
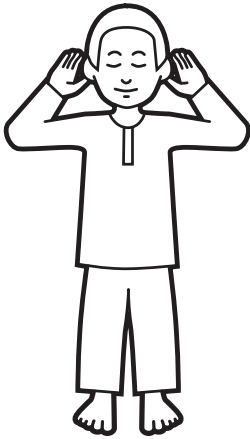

# My actions of Salaa

Match the different salaa positions with the correct name.

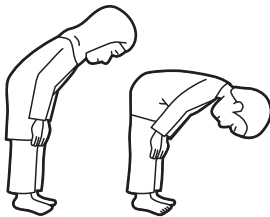
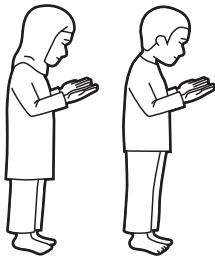
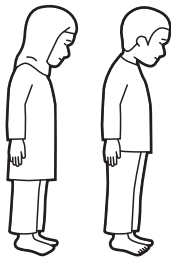
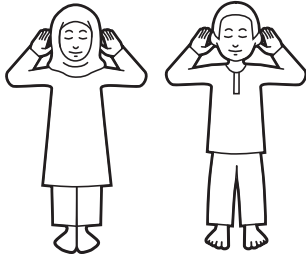

Sajda

Qunoot

Rukoo

Qiyam

Takbeeratul  
Ithram

Juloos





# Sajda

---

Colour the seven parts which must touch the ground when doing sajda.  
What do you recite in sajda?

Colour the pictures.

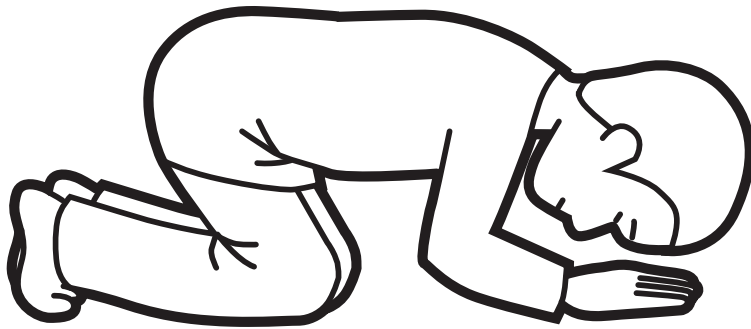
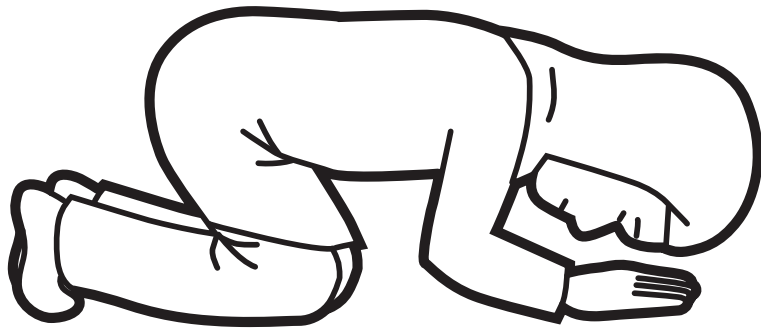

# Fasting

---

Draw and/or write how you fast with different parts of the body.

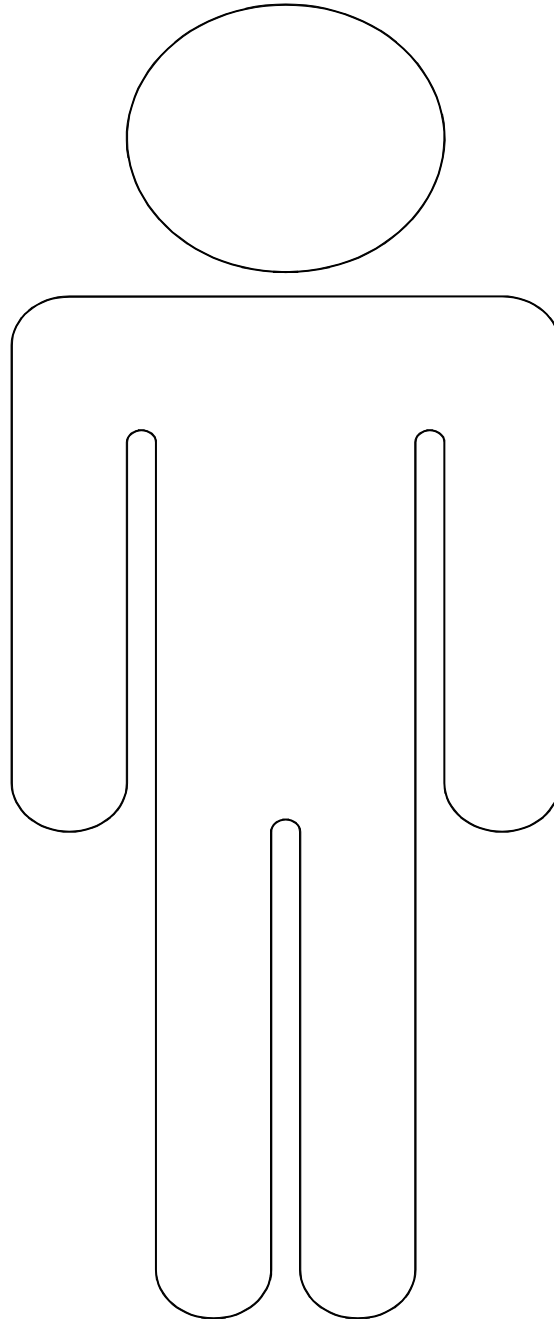

# Sawm

Circle all the things that would break sawm.

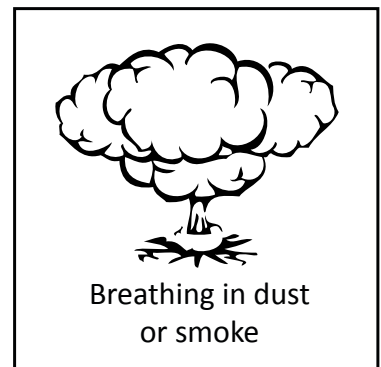
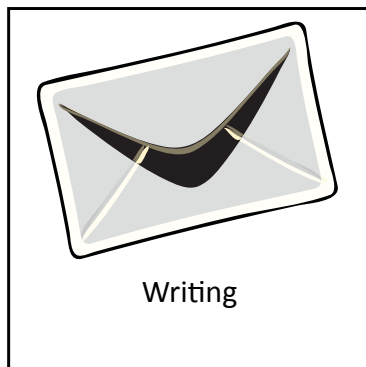
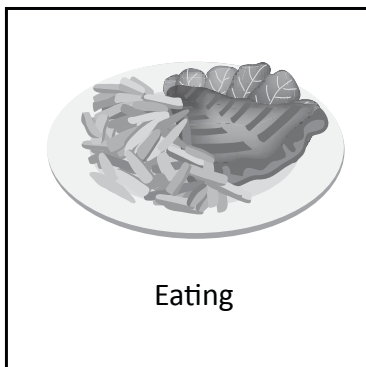
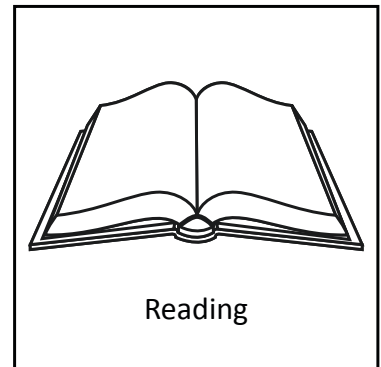
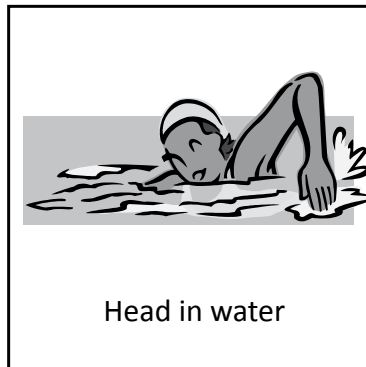
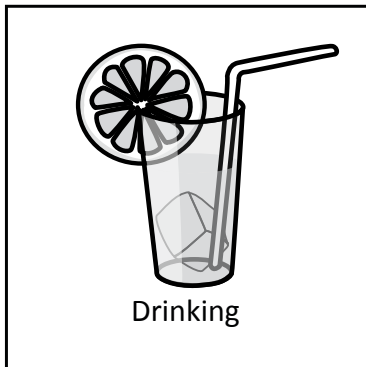
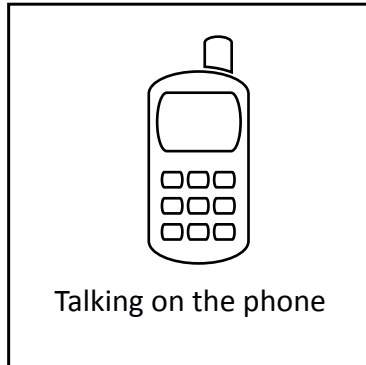

# Fasting - Sawm

Put a cross on the things NOT allowed when fasting.

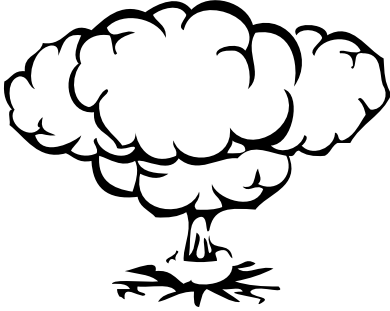

Breathing in dust or smoke

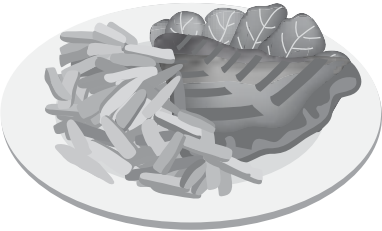

Head in water



Having a shower

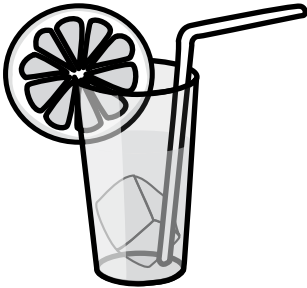
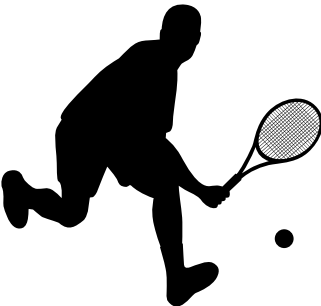

# Fruits for Fasting

---

In each of the fruits below write a benefit (fruit) of fasting.  
You may colour the fruits

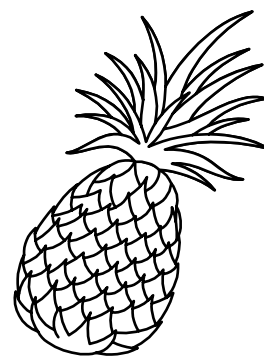
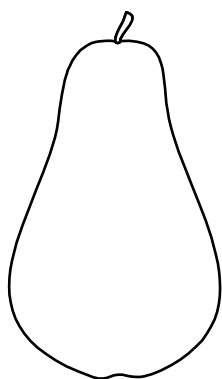
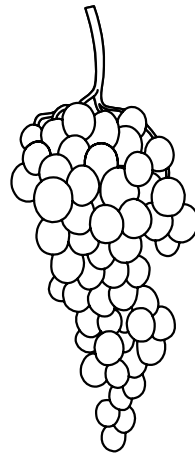
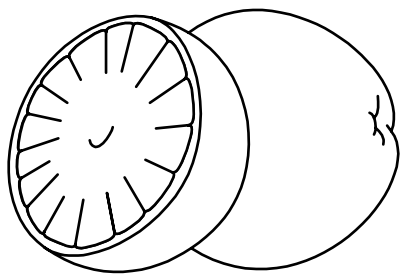
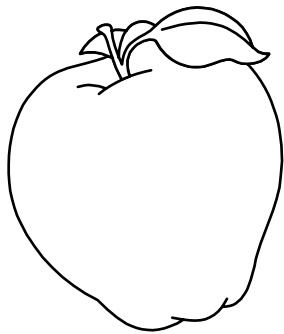

Eiman, taqwa, nearness to Allah, self-control, forgiveness of sins.....



# Amr bil Ma'ruf & Nahyi anil Munkar

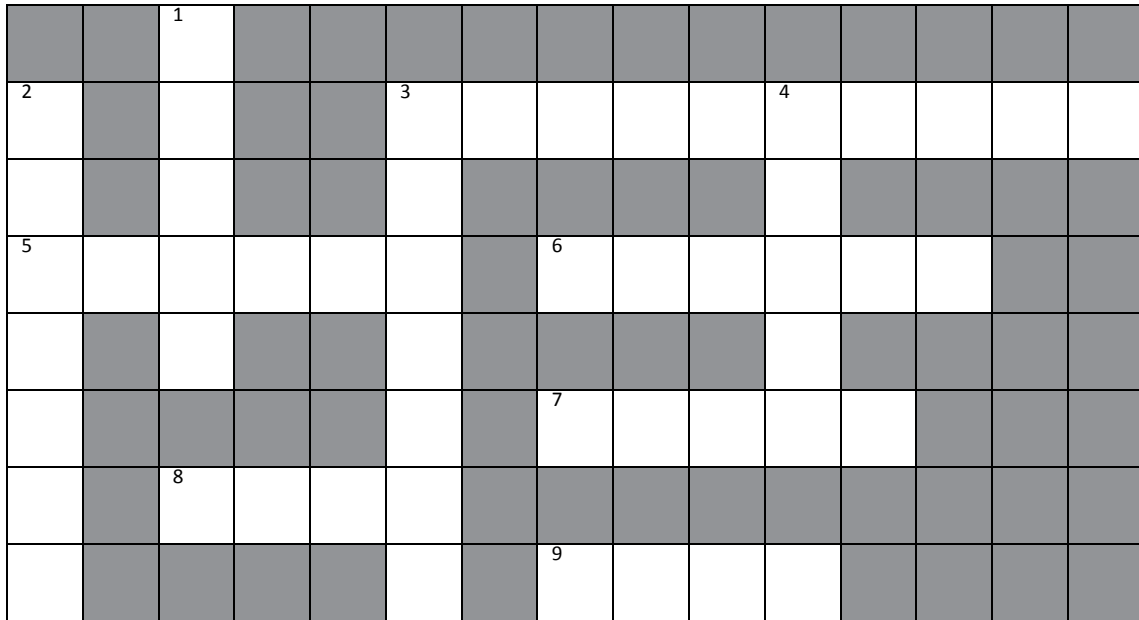

### Across

3. Allah says in the Qur'an, that those who do amr bil ma'ruf and nahyi anil munkar are .....
5. One of the Sunni schools of thought
6. The followers of Abu Hanifa
7. Amr bil Ma'ruf and Nahyi anil Munkar are .....
8. Munkar
9. Ma'ruf

### Down

1. He went to the court of the Sultan with his shoes under his armpit
2. One of the Sunni schools of thought
3. Like ..... in the fathomless ocean .....
4. One of the Sunni schools of thought



# A day in my life

---

Mark the areas where you could make better use of your time in red.



Fajr



Morning



Dhuhr



Afternoon



Maghrib



Evening /  
Night



# One good deed a day only for Allah

---

In your diary below write down a good deed that you would do each day.

**Monday**

**Tuesday**

**Wednesday**

**Thursday**

**Friday**

**Saturday**

**Sunday**





# Good thoughts about others

---

In the hearts below write down names of 5 people you know.  
Then write one good thing about them.

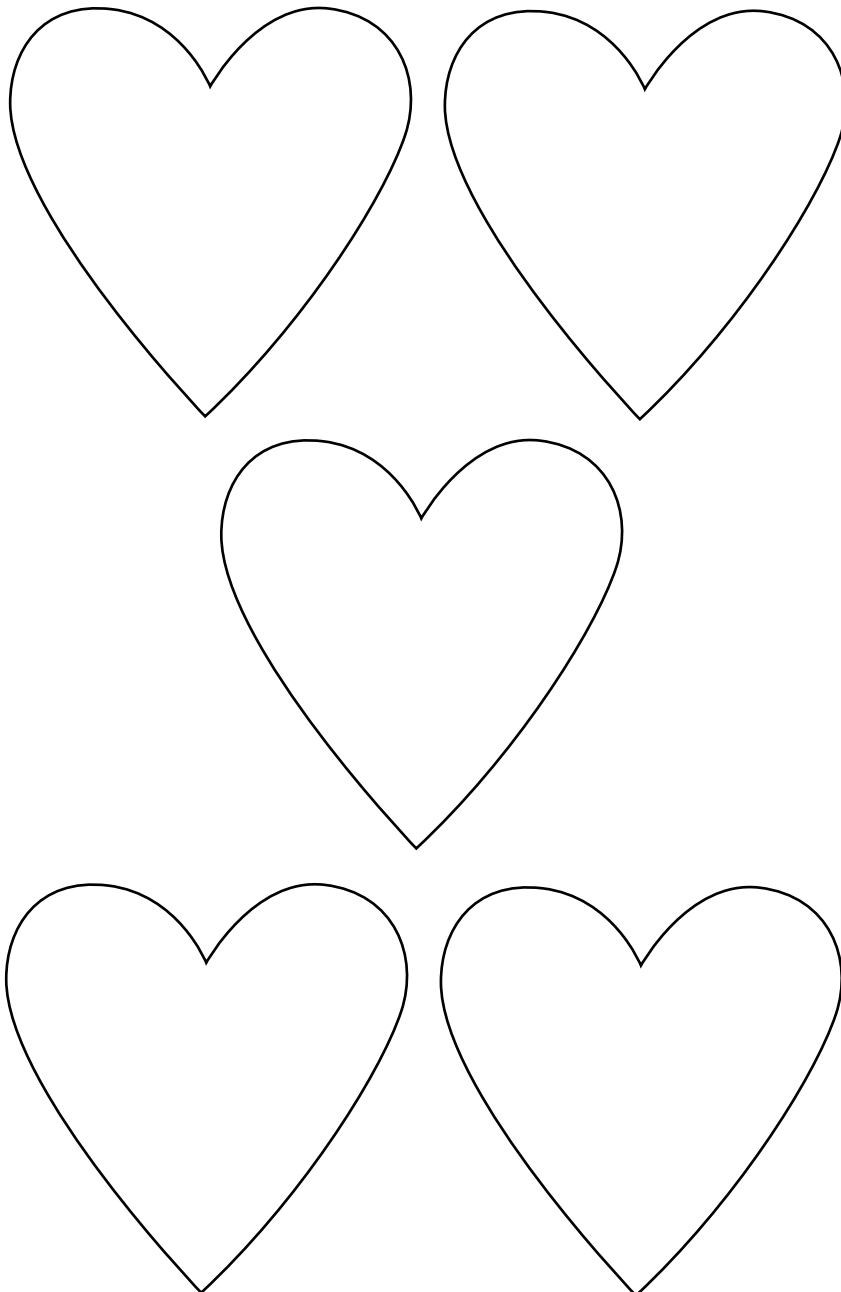

# Managing Anger

---

Colour the picture below. It appears that one man is being very angry. If he is saying something bad, what should the other person say to him?



# Knowledge...

---

How do you increase your knowledge?  
Circle the answers

Madrasa

School

Watching  
TV

Qur'an Classes

Parties

Majalis

Reading good  
books

Reciting  
Qur'an

Teaching

Observing  
others

Computer  
games

Shopping

Fighting

Discussing

Sleeping



# Parents Dua

---

“...Lord have mercy on them (parents) as they had mercy on me when I was little...”

When you become a parent (inshallah) what qualities do You think are the most important for a parent. Put the qualities below in order of importance.

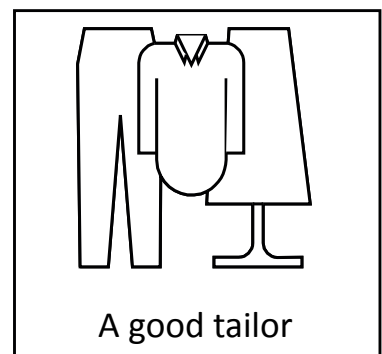
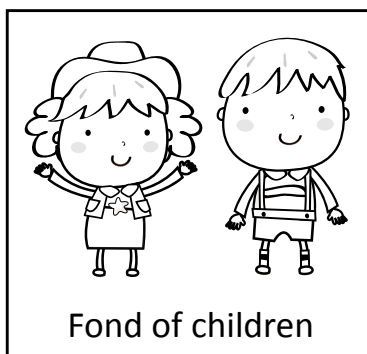
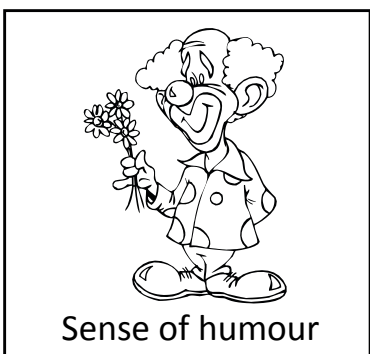
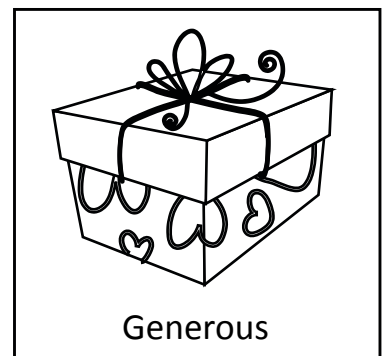
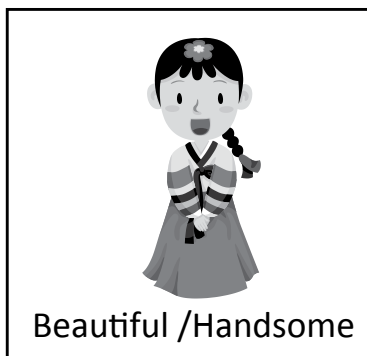
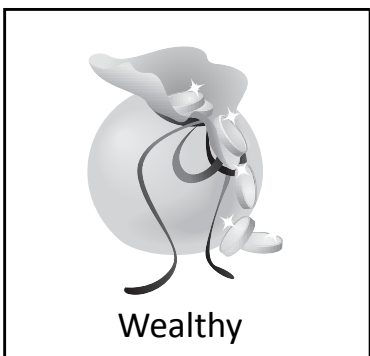
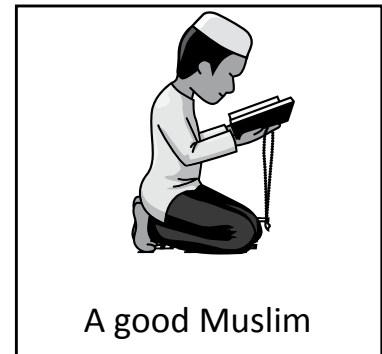
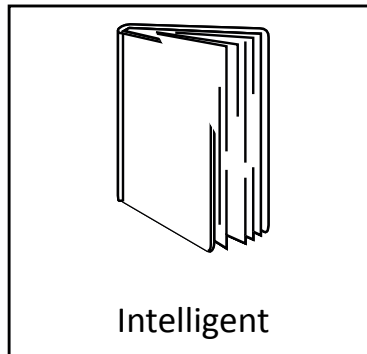
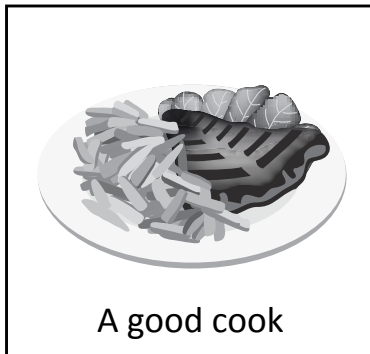

# Kindness to Parents

---

Allah wants us to be kind to our parents.

In the boxes below draw pictures of how you can be kind to your parents:

E.g. By helping tidy your toys



# Be Cheerful

---

Write or draw the things that make you smile.

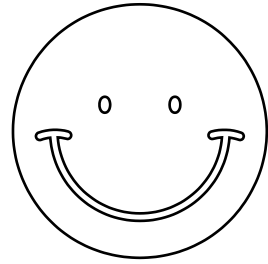

Also write or draw the things that do not make you smile!

Who do you smile for the most?



# Wrong Actions

Some times we do things that we know are wrong. Why do we do these wrong things?

In the table below:

1. Write down **5 things / acts** that you do which you know are **wrong**.
2. Write down the **reasons** for doing these wrong things.
3. Write down the **benefits** that **you** and your **friends** would get if you did not do those wrong things / acts.

WRONG/BAD ACTIONS	WHY DO I DO THESE WRONG BAD ACTIONS	BENEFITS TO MYSELF IF I DO NOT DO THEM	BENEFITS TO MY FRIENDS IF I DO NOT DO THEM
Gossip & backbite	To be part of the group of friends	I would not get sins for gheebat	I would not hurt peoples feelings



# Headscarves

---

Create different styles of headscarves:

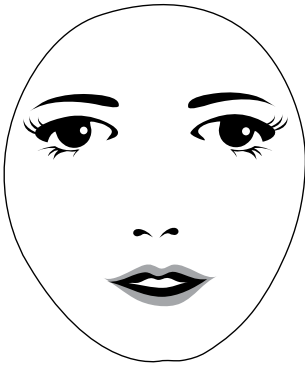
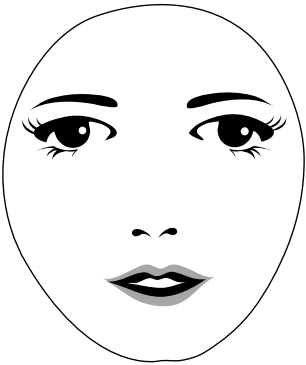
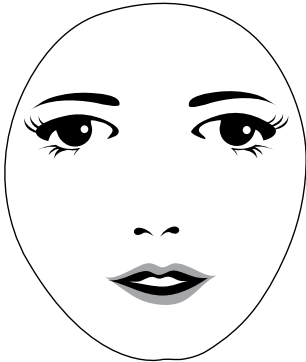
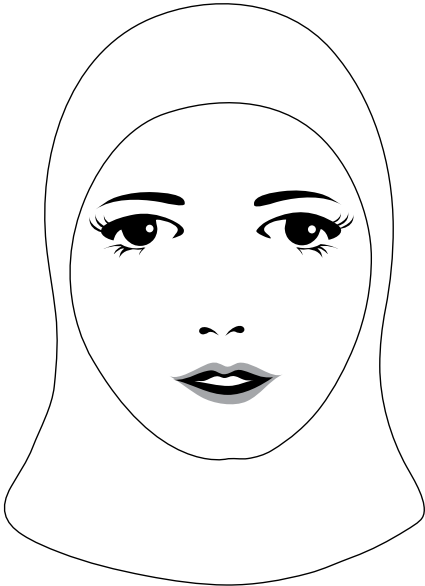



# Abaya

---

Design your own Abaya



# Hijab

---

Design your own hijab outfit

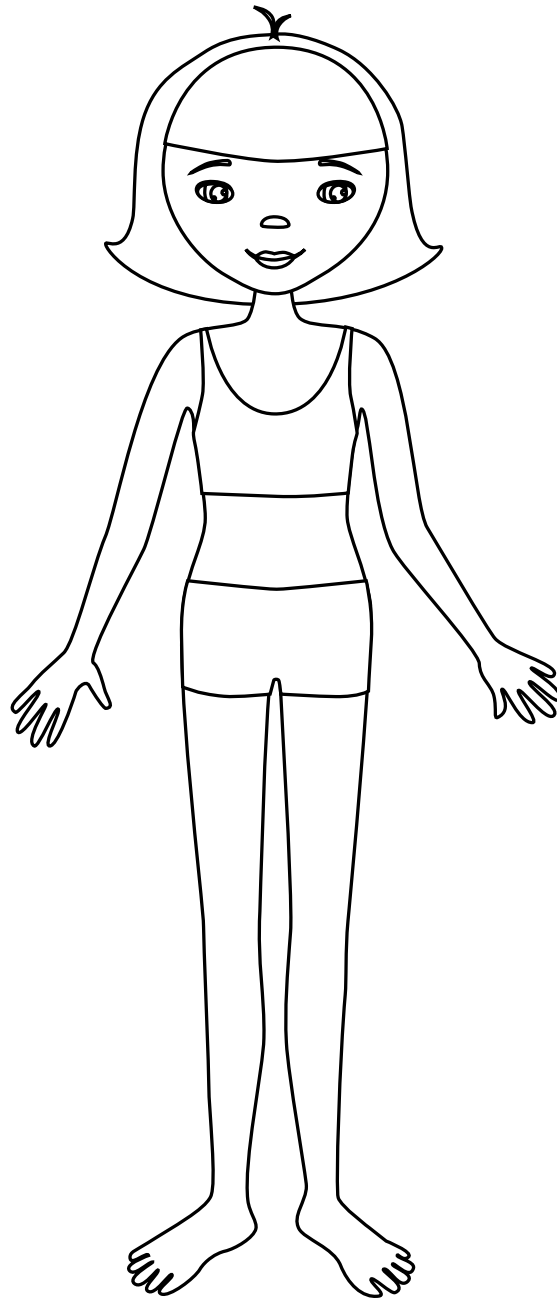

# Helping a Dying Person

Fill in the circles of what we can do to help a dying person at the of death...

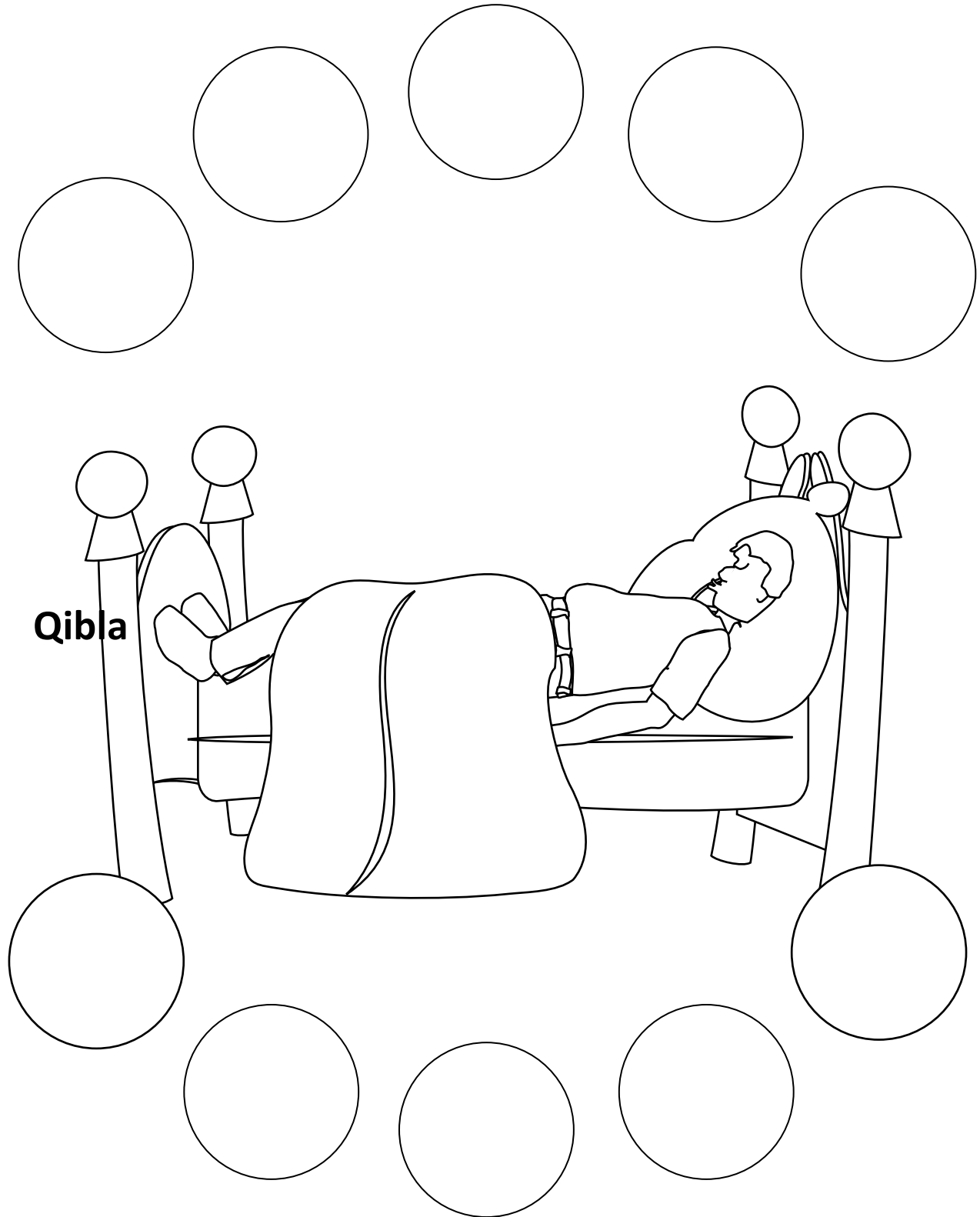

# Helping the deceased

---

In the circles below draw all the things you can do to help the deceased.

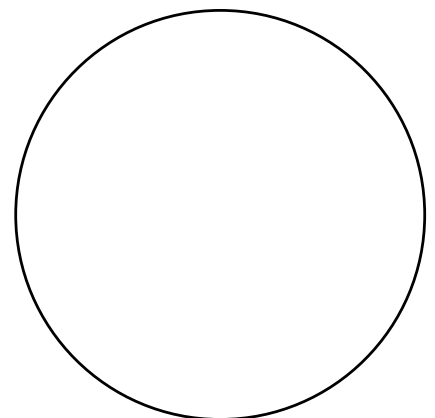
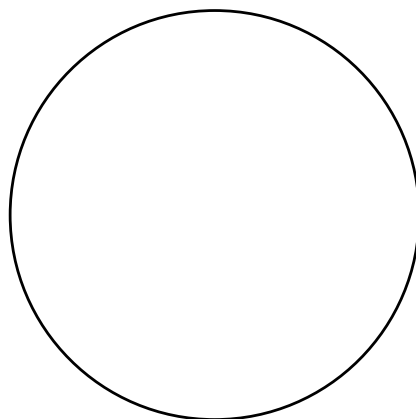
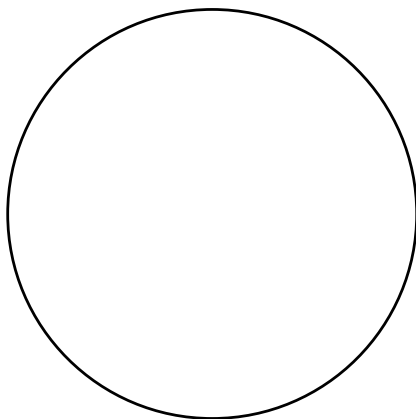
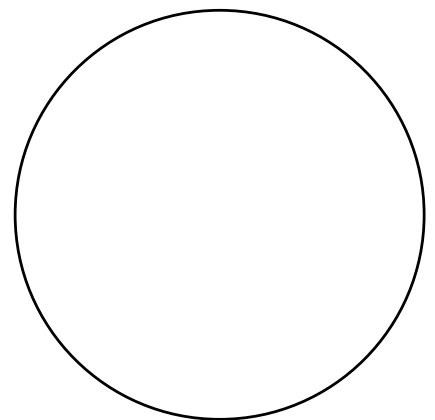
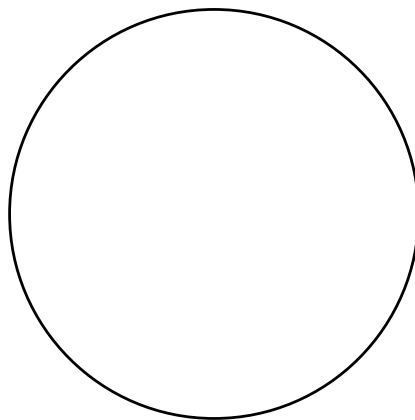
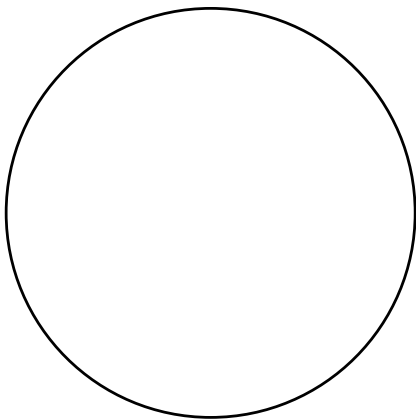
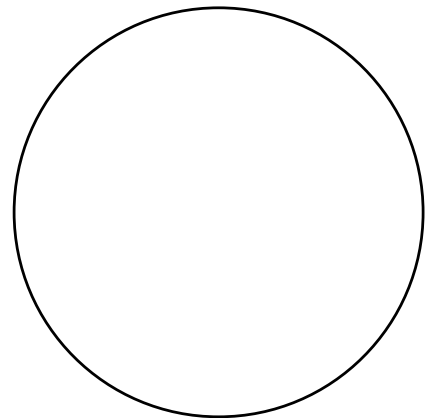
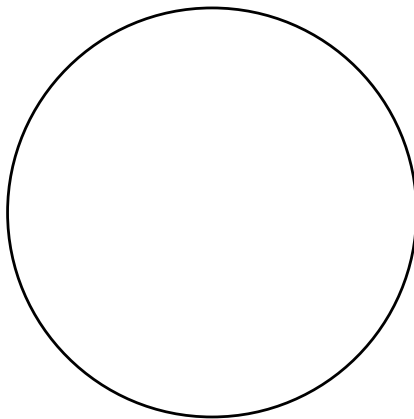
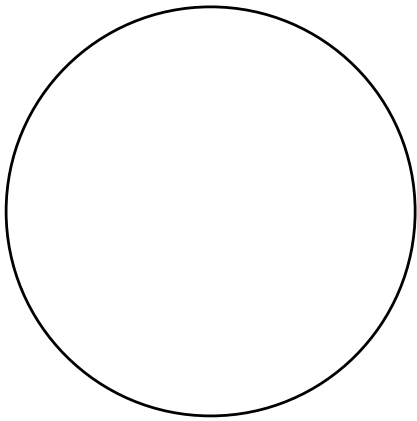

# Jareeda

It is recommended to write the names of the Masumeen on the Jareeda

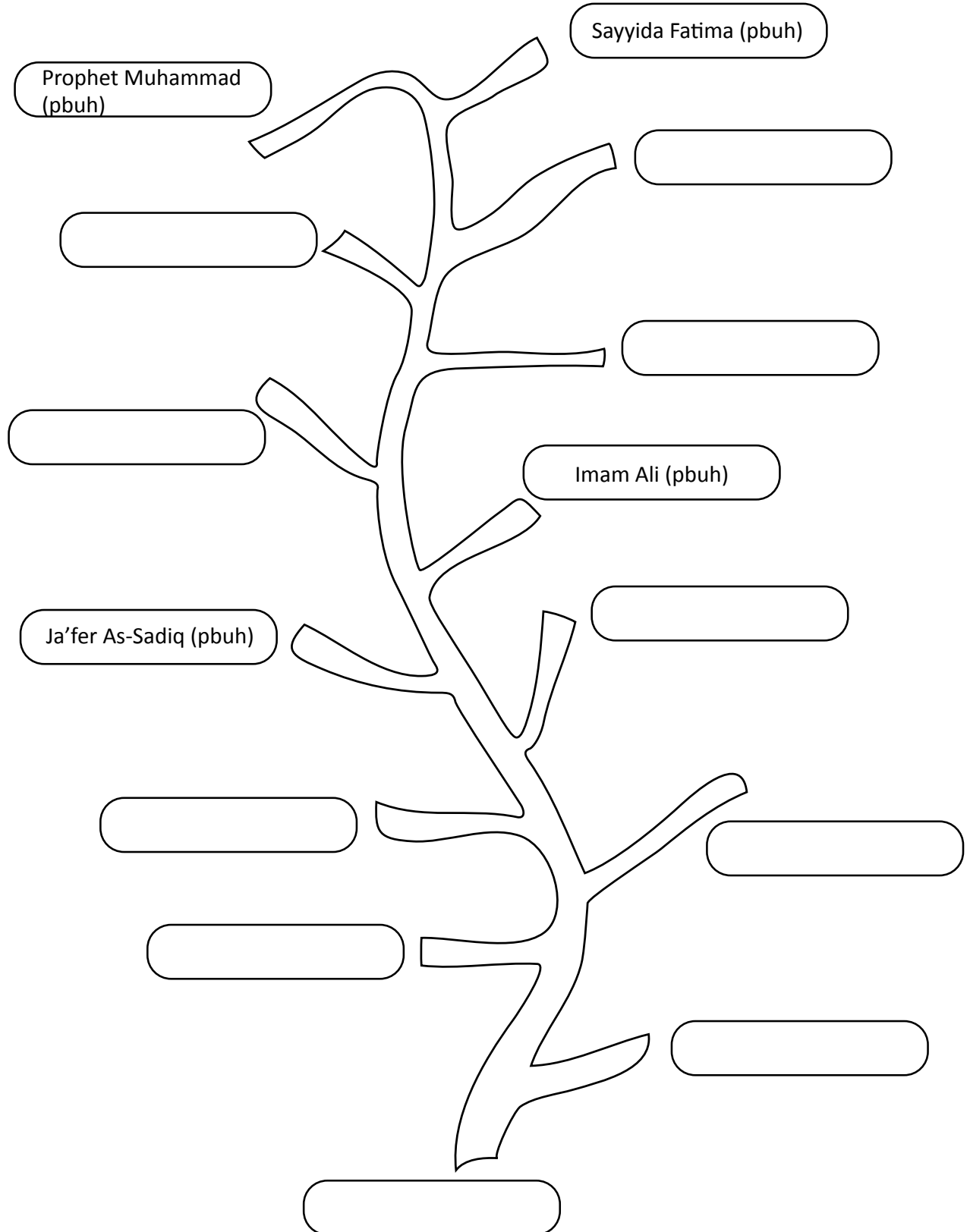

# Responsibilities - My Will

---



# Responsibilities - My Special Requests

---



# **Responsibilities - People I need to ask for forgiveness**

---





# Responsibilities - My Qadha Salaa

---



# Responsibilities - My Qadha Fast

---



# Responsibilities - Debts

---



# Word Search

I	Q	W	E	R	T	Y	U	I	O	P	S	A	S
H	U	N	T	R	T	D	F	G	H	J	I	L	Z
T	X	C	V	B	N	M	N	B	V	C	D	X	Z
I	L	K	J	H	G	F	T	D	S	A	R	P	O
D	I	U	T	T	R	E	W	A	Q	W	E	R	T
H	Y	K	A	A	F	U	R	U	K	I	O	P	A
A	M	N	L	V	C	X	Z	L	K	F	J	H	H
A	F	D	Q	A	G	P	O	I	U	Y	E	T	N
R	Q	W	E	R	H	Y	K	U	I	O	P	E	E
S	D	F	E	N	U	H	J	H	K	L	M	N	E
W	E	R	N	Y	S	U	I	O	A	A	D	F	T
M	G	W	I	L	L	Q	W	E	R	L	T	Y	U
M	N	B	V	C	X	Z	K	J	H	F	I	D	S
O	I	K	A	F	A	N	U	Y	T	R	E	S	U
S	A	L	A	T	U	L	M	A	Y	Y	I	T	A

Ihtidhaar

Tahneet

Takfeen

Talqeen

Ghusl

Kafan

Sidr

Will

Kaafur

Khalis

Salatul Mayyit



# Terminology - The Qur'an

---

Match the columns

1 Sura

Aya

1 Juz

Harf

Nabi

1 Manzil

Imam

Huruf

Ambiya

114 Suwer

Manazil

Aimma

30 Ajzaa

Ayaat



# The Study of Qur'an

---

Studying the Qur'an is like gathering fruits  
from a tree.

With constant guidance from the farmer -

First shake the tree, that the ripest might fall.  
Then shake each branch and twig,  
And then look under every leaf.

With guidance from the Ahlul Bayt -  
First recite correctly and carefully the Qur'an as  
a whole to get it's immediate benefits.

Then shake each branch - give attention to each sura,  
its content and message.

Then shake each twig - ponder over every aya.  
Then look under each leaf - study every word.

Write the names of the suwer you know around the tree.



# Suratul Feel

## The Year of the Elephant

---

Colour the picture below



# Al-Fatihah - The Opening

---

Decorate the page with the no 7 to remind you of the 7 verses in this sura. In the book write 15:87 – the verse which tells us that this sura is called Saba' Mathani (the seven verses revealed twice).

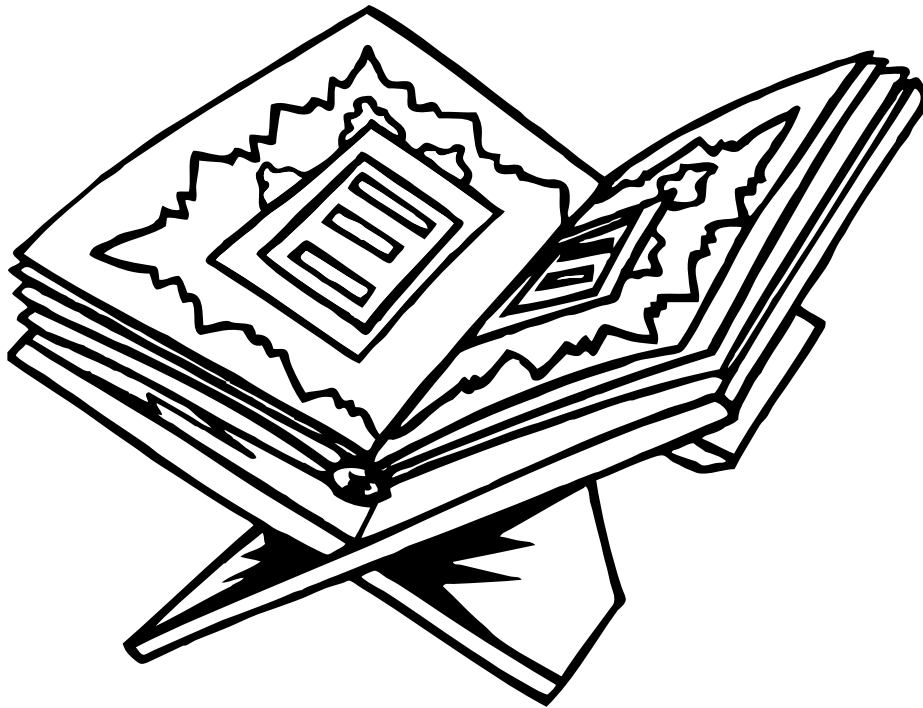

Draw pictures to show that this sura is recited in:

- i) Every salaa
- ii) As a cure for illnesses
- iii) For heart problems
- iv) As a blessing for those who have died (Marhumeen)





# Al-Baqarah - The Cow

---

The sura takes its name from the cow which Prophet Musa (pbuh) asked his people to sacrifice. They asked lots of questions about what sort of cow it would be. Read verses 67-71 of Suratul Baqara to find out how you should colour the cow.

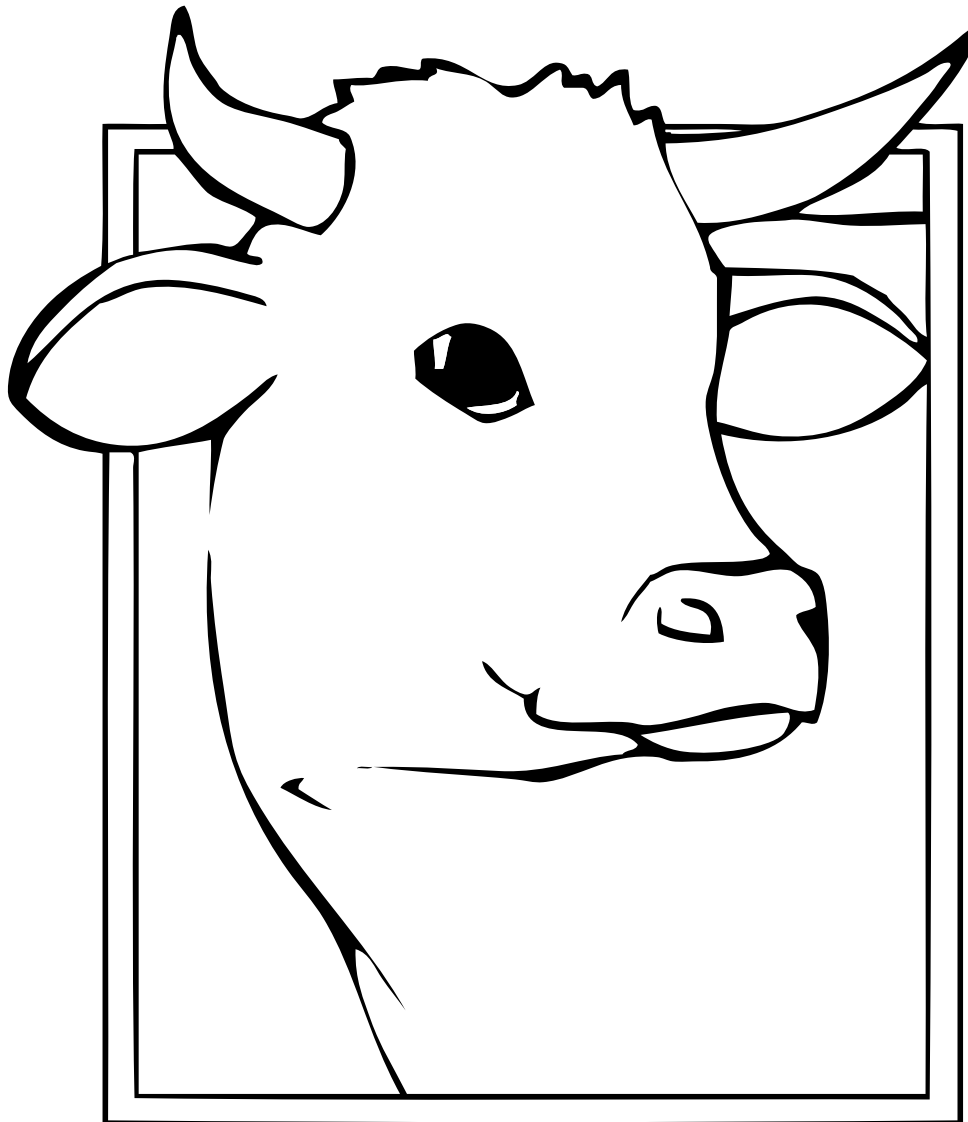

# Suratul Baqarah - The Cow

---

[2:67] And when Musa said to his people: Surely Allah commands you that you should sacrifice a cow; they said: Do you ridicule us? He said: I seek the protection of Allah from being one of the ignorant.

[2:68] They said: Call on your Lord for our sake to make it plain to us what she is. Musa said: He says, Surely she is a cow neither advanced in age nor too young, of middle age between that (and this); do therefore what you are commanded.

[2:69] They said: Call on your Lord for our sake to make it plain to us what her color is. Musa said: He says, Surely she is a yellow cow; her color is intensely yellow, giving delight to the beholders.

[2:70] They said: Call on your Lord for our sake to make it plain to us what she is, for surely to us the cows are all alike, and if Allah please we shall surely be guided aright.

[2:71] Musa said: He says, Surely she is a cow not made submissive that she should plough the land, nor does she irrigate the tilth; sound, without a blemish in her. They said: Now you have brought the truth; so they sacrificed her, though they had not the mind to do (it).



# Al'Imran - The Imran Family

---

Who are the members of the family of Imran?

Colour the picture and put a name tag. Here's a clue – The mum was Hannah and the baby grew up to have a baby called Prophet Isa (pbuh).



[3:33] Surely Allah chose Adam and Nuh and the descendants of Ibrahim and the descendants of Imran above the nations.

[3:34] Offspring one of the other; and Allah is Hearing, Knowing.

[3:35] When a woman of Imran said: My Lord! surely I vow to Thee what is in my womb, to be devoted (to Thy service); accept therefore from me, surely Thou art the Hearing, the Knowing



# Al-Nisa' - Women

---

What should these women be wearing if they were going out? Colour the picture to make sure they are wearing hijab. Hijab means wearing clothing that covers the body and hair.....



# Al-Ma'idah - The Table

---

Al Ma'idah means both a table with food and a plate of food. The companions of Prophet Isa (pbuh) asked whether Allah could send down food from heaven. A table was sent down suspended by golden chains with bread and fish on it. (AL MIZAN VOL 12 Pg 56)

Draw 9 loaves of bread and 9 fish on the table.

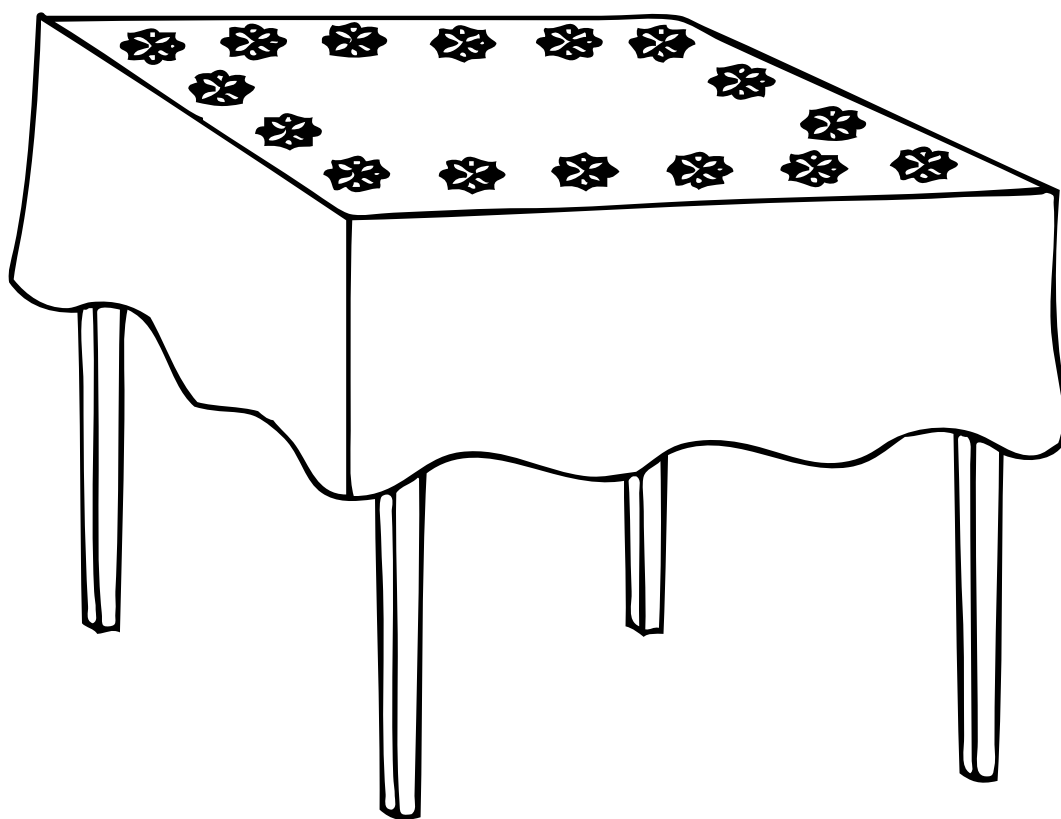

[5:112] When the disciples said: O Isa son of Marium! will your Rabb send down to us food from heaven?



# Al-An'am - Livestock

---

Draw animals that carry things for us like camels; those that we eat like cows and sheep and colour the picture.



[6:142] And of livestock (He created) beasts of burden and those which are fit for slaughter only.....



# Al- A'raf - The Heights

---

A'raf is the fortress that separates Heaven (Janna) and Hell (Jahannam). In the picture draw a fire on one side and a garden on the other.



[7:48] “And the dwellers of the most elevated places shall call out to those whom they will recognize by their marks saying: Of no use was to you your hoarding and your behaving with pride....”



# The Holy Qur'an -Ruku

---

## ACTIVITY:

Below is a picture of a RUKU. Look it up in the Qur'an, you will find it on almost any page on the margin. Explain what the labelled Arabic Numbers mean and also complete the sentence below:

A Ruku is \_\_\_\_\_ .

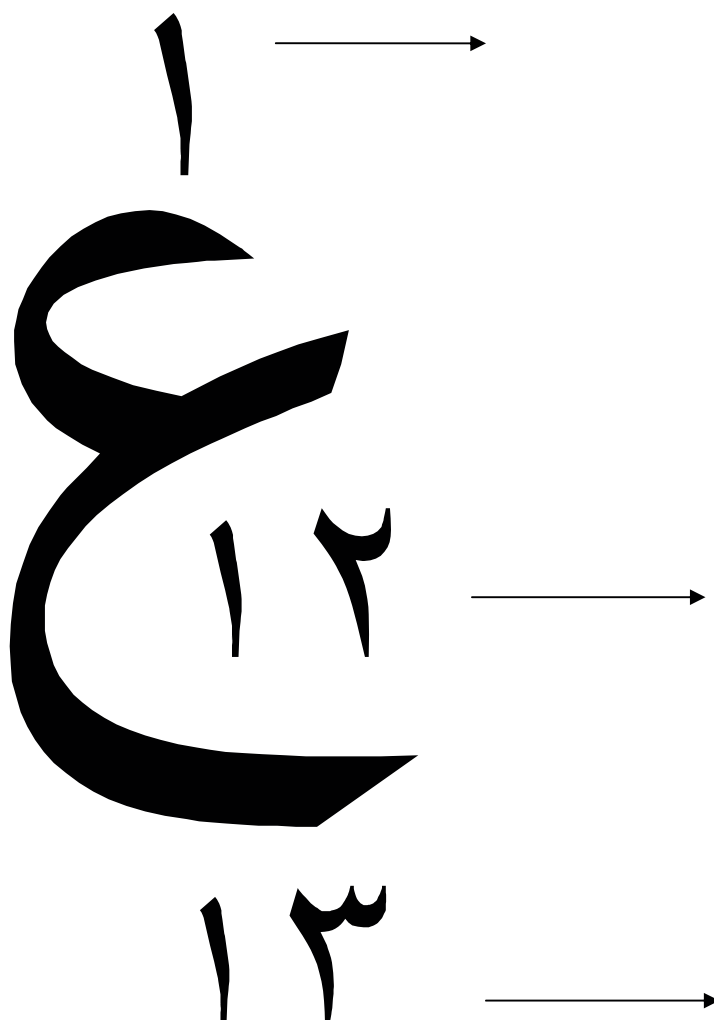



# Q114 - Match the columns

---

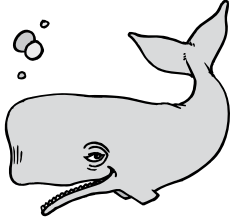

1

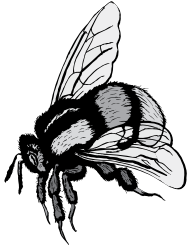

31



16



10



22



# Q114 - Match the columns

---



99

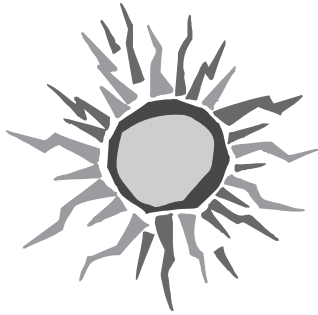

105



90

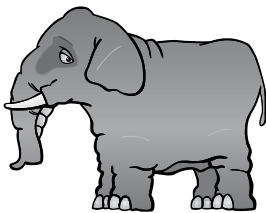

111



91



# Q114 - Match the columns

---

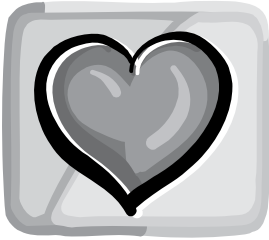

62

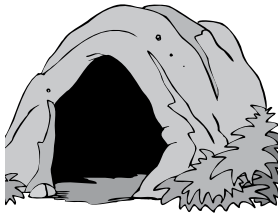

36



80



18



53



# Q114 Test

---

1. Which sura starts with the letter nun
  - a) 56
  - b) 68
  - c) 23
2. What is the group of suwer 40-46 called
  - a) Meemaat
  - b) Ra'aat
  - c) Hawameem
3. Sura No 12 is:
  - a) Surat Yusuf
  - b) Surat Yunus
  - c) Surat Muhammad
4. Which sura is known by both the names Bani Israil and Israa
  - a) 13
  - b) 71
  - c) 17
5. Who was the Qur'an revealed to:
  - a) 11
  - b) 19
  - c) 47
6. The 4 Quls are:
  - a) 109, 112, 113 & 114
  - b) 108, 105, 102 & 103
  - c) 110, 112, 113 & 114
7. Which sura refers to the frowning of those who were with the Prophet (pbuh) when the blind man came?
  - a) 80
  - b) 32
  - c) 84
8. Which is the only sura that begins with an attribute of Allah (Asmaul Husna)
  - a) 55
  - b) 01
  - c) 50



9. Which sura is known as the heart of the Qur'an?  
d) 26  
a) 36  
b) 46
10. This is the only sura that bears the name of a woman  
a) 29  
b) 19  
c) 59
11. Which sura is twinned with Suratul Feel  
a) 105  
b) 106  
c) 103
12. The sixth day of the week is  
a) 86  
b) 62  
c) 76
13. They are made out of smokeless fire  
a) 65  
b) 76  
c) 72
14. The first ayaat revealed are in this sura  
a) 96  
b) 69  
c) 99
15. This is the first sura of Juz 'Amma  
a) 87  
b) 98  
c) 78
16. This sura is recited in Laylatul Qadr and takes its name from the spiders web  
a) 34  
b) 29  
c) 60
17. Al Mujadilah (The Pleading one)  
a) 32  
b) 60  
c) 58



18. Al Ahzab (The Coalition)

- a) 22
- b) 44
- c) 33

19. Al Balad (The City)

- a) 60
- b) 90
- c) 30

20. This sura is recited in every salaa

- a) 01
- b) 11
- c) 111



# Qur'an and Dua

---

You may want to make a frame for the picture below and hang it in your bedroom.

When we want Allah to talk to us we read the Qur'an.  
When we want Allah to talk to us we recite Dua.

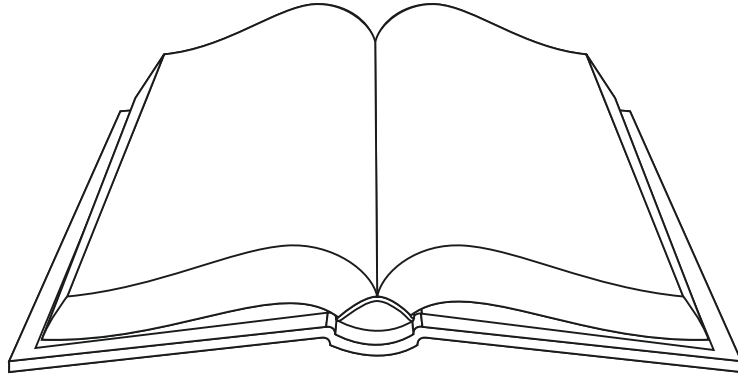

“Brighten your home by reading the Qur'an”  
Prophet Muhammad (pbuh)

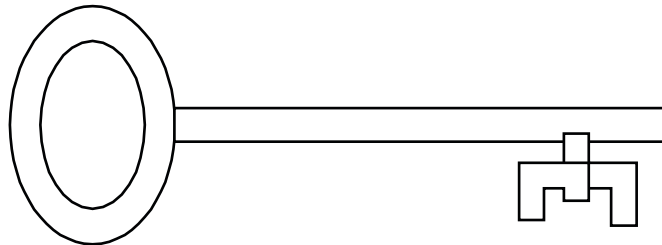

Make Dua the key that opens and closes your every night and day.



# Qur'an as a Healer

---

“We have sent down in the Qur'an that which is healing and a mercy to those who believe”  
Suratul Bani Israil (17:82)

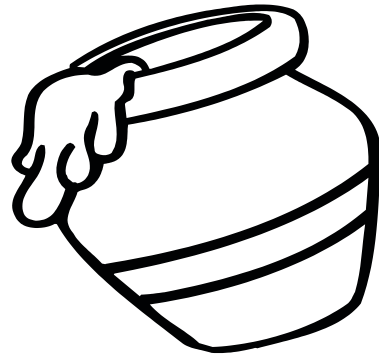
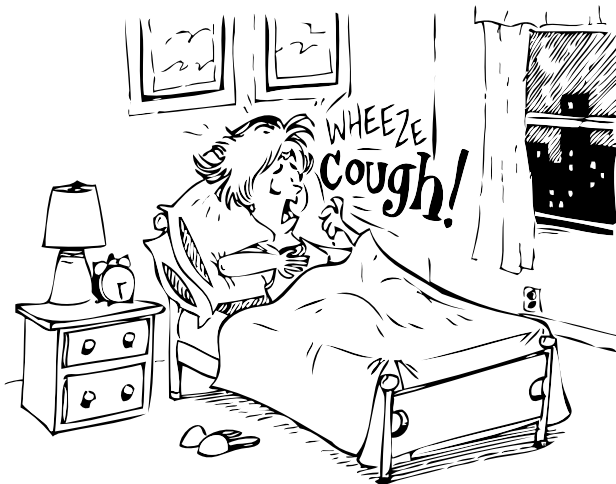
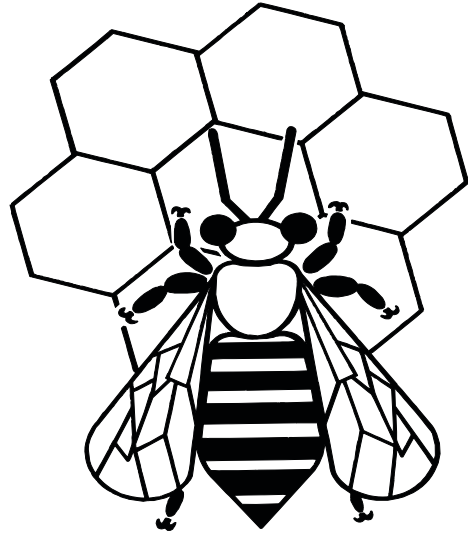
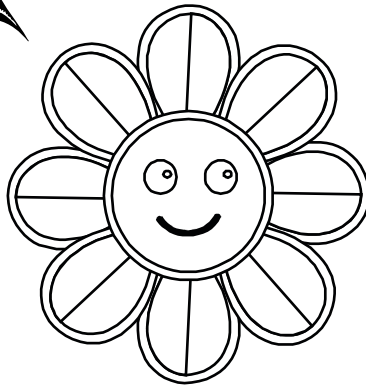
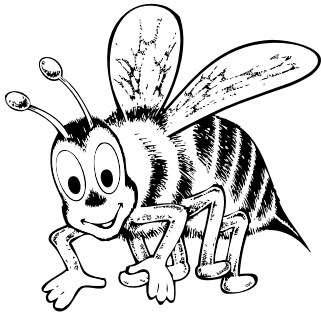

Honey heals many illnesses, in which Sura does Allah mention the bee and honey as a healer?

---





# Animals in the Qur'an

Match the pictures with the arabic names.

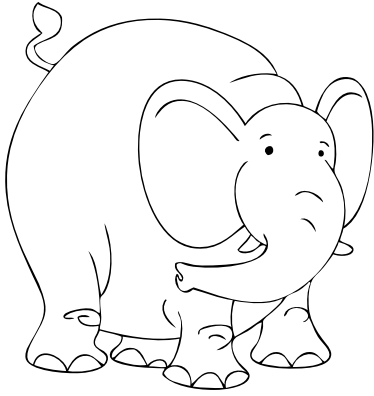

..... بَقْرَةٌ

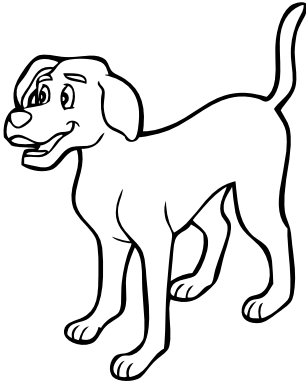

..... فَيْلٌ

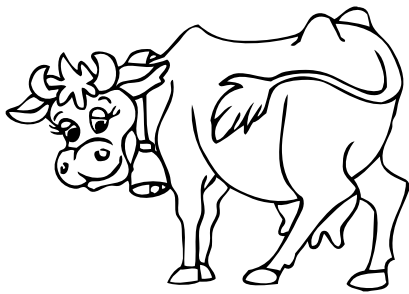

..... كَلْبٌ



..... تُعْبَانٌ



# Insects in the Qur'an

Match the pictures with the arabic names.

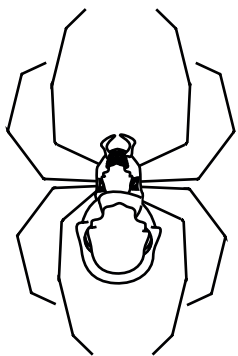

Spider

نَحْلَةٌ

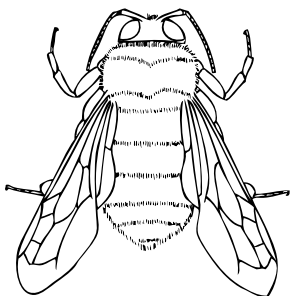

Bee••

نَمَلَةٌ

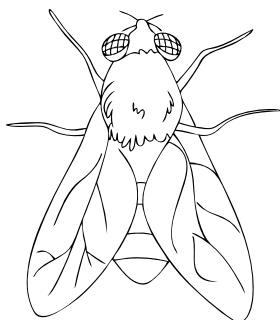

Fly

عَنْكَبُوتٌ

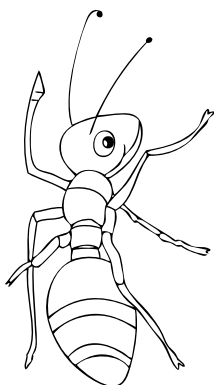

Ant

ذُبَابَةٌ



# Qur'an in my life

---

Qur'an is not there only to be read but also to be applied in our life.

Colour the picture below of children reading the Qur'an.

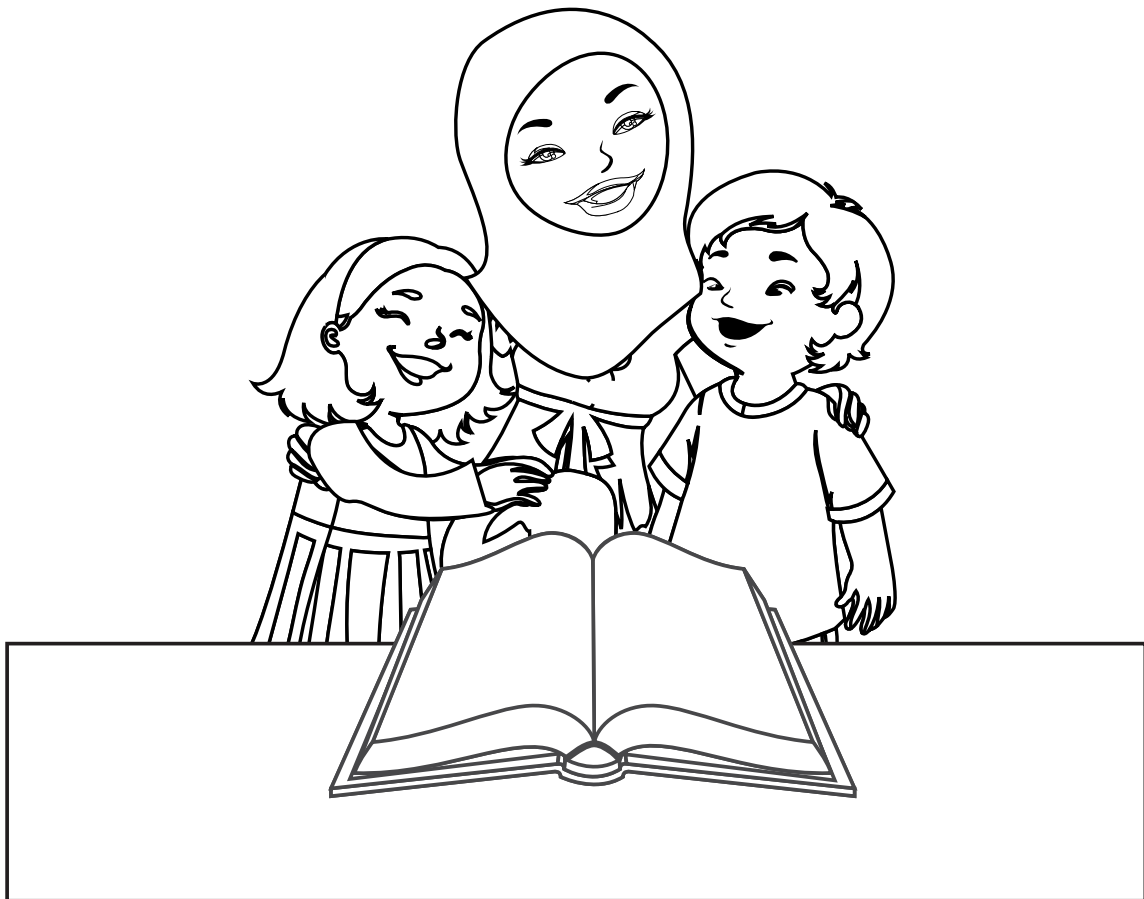

Ask your parents if they can help you find a verse of a Surah that you know or recite often which you can act upon. Ask them to help you write the meaning of that verse in the box below.



# The Ark of Prophet Nuh (pbuh)

---

Colour the ark below.

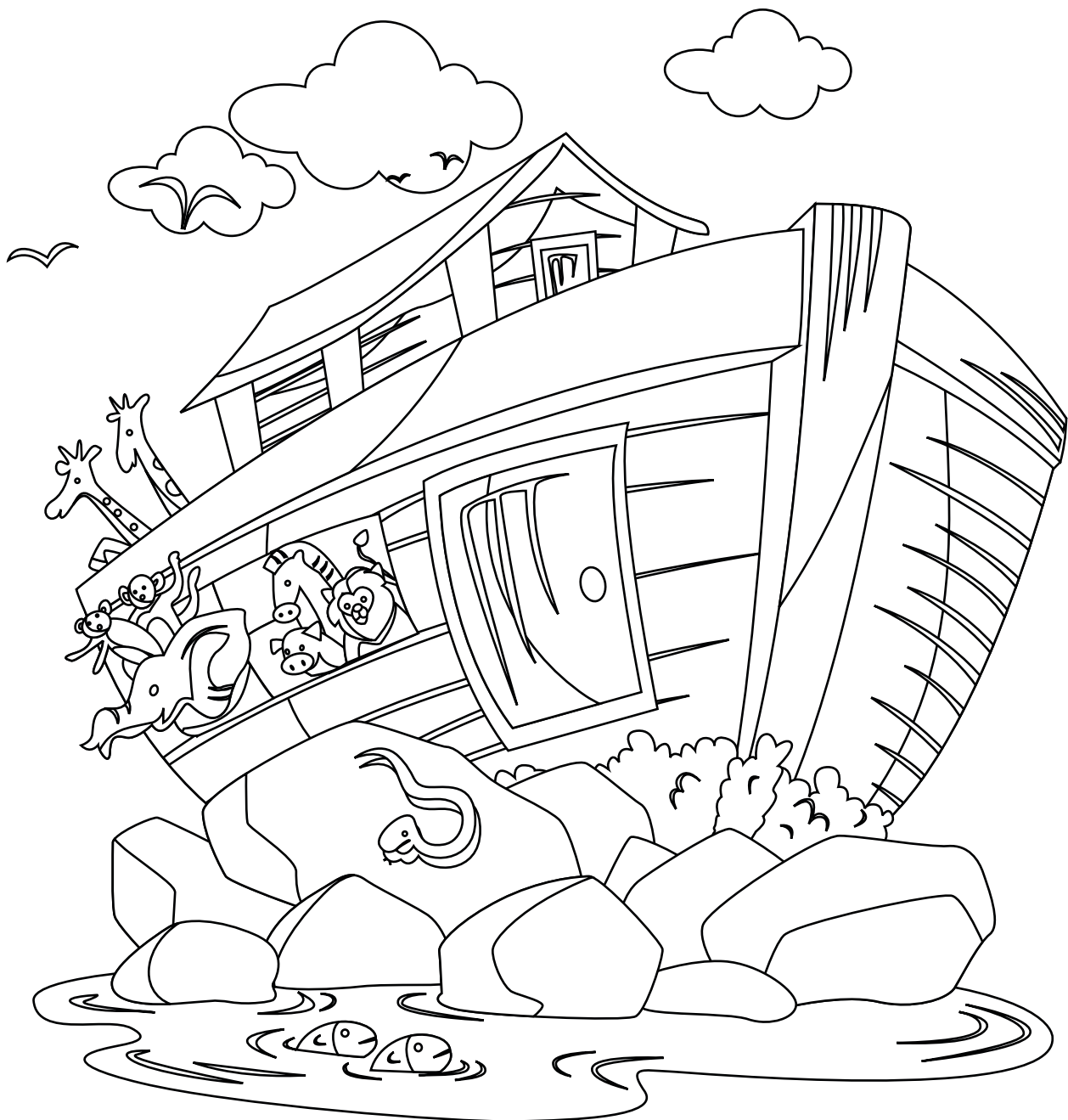

# Animals on the Ark of Prophet Nuh (pbuh)

Glue page on to card and colour. Cut the animals and fold the base.  
Position on and around the ark.

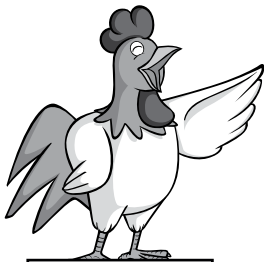

Fold Under

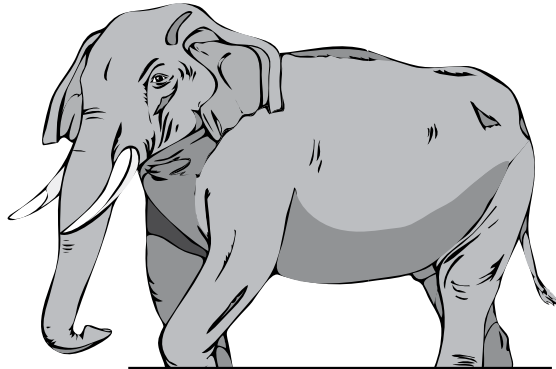

Fold Under

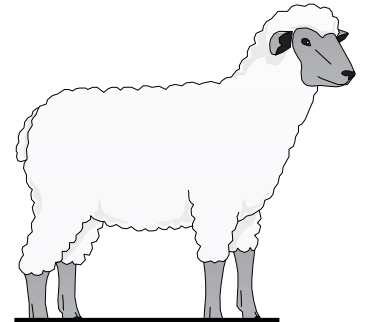

Fold Under



Make a small slot  
inbetween the parrot  
and put on the egde  
of the ark



Fold Under

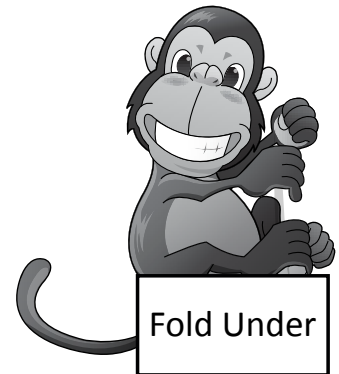

Fold Under

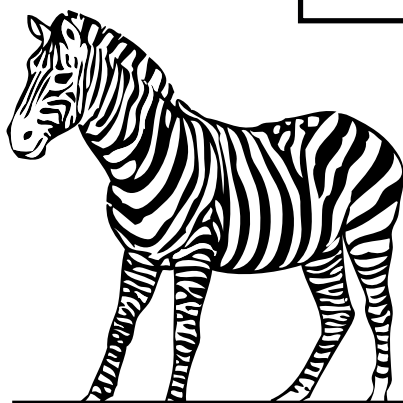

Fold Under



Fold Under



# Prophet Ibrahim & The Fire

---

Colour the picture. What did the lizard do when he saw Prophet Ibrahim put in the fire by Namrood.

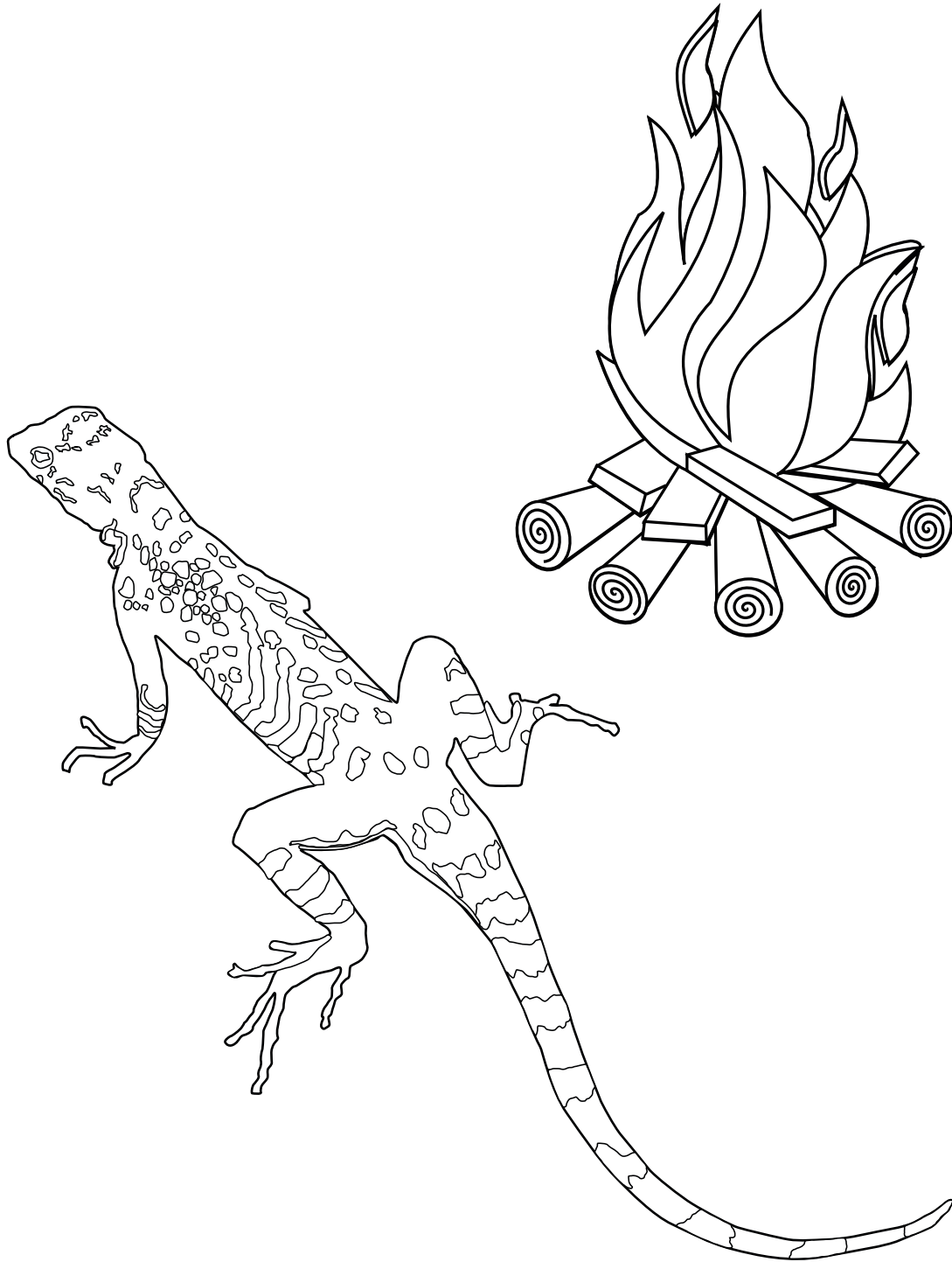

# Ibrahim & idols

---

Prophet Ibrahim broke all the idols except one to teach the people that whatever they were worshipping couldn't give / do anything for them.

We also have our little "idols" which takes us away from God.

In the boxes below write down your "idols" and how you would break them.

My "idol" is.....	I will break my "idol" by.....



# Zam Zam

---

Zam Zam means abundant (plenty) of water.

Write and / or draw all the ways in which you use water in your life.





# Prophet Yunus (pbuh)

Colour the picture below

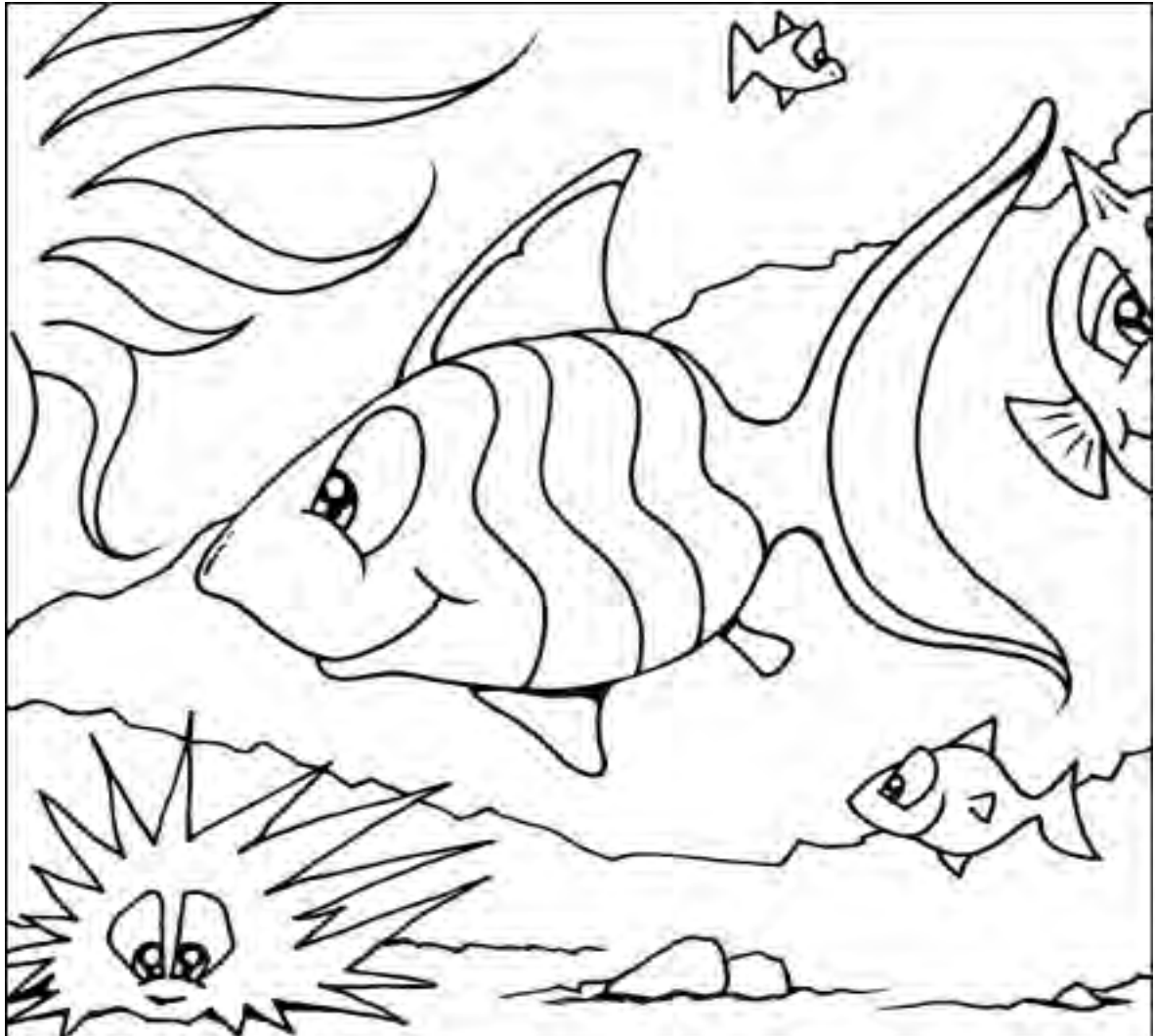

Fish  
 Ninevah  
 Obey  
 Plant  
 Prayed

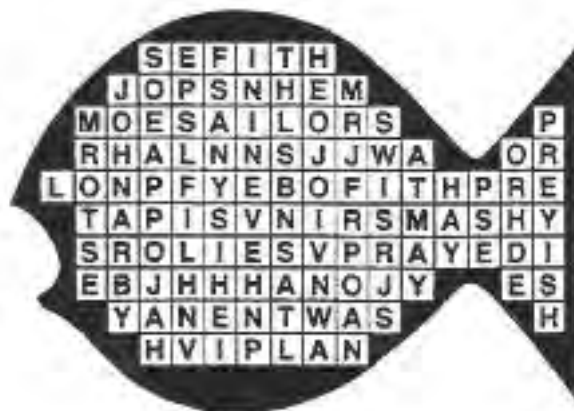

Sea  
 Sorry  
 Sailors  
 Storm



# Prophet Dawud (pbuh)

---

Prophet Dawud (pbuh) killed Jalut with a small stone from a catapult.

We can kill bad deeds with one small quality of good akhlaq. e.g. Lies can be killed with the quality of truth.

Draw lines to match what good quality kills bad deeds.

**LYING**

**ASKING  
PERMISSION**

**STEALING**

**POLITE**

**MEAN**

**GENEROUS**

**RUDE**

**TRUTH**

**SELFISH**

**KIND**



# Family Tree of Prophet Muhammad (pbuh)

---

Fill in the blanks of the family tree.

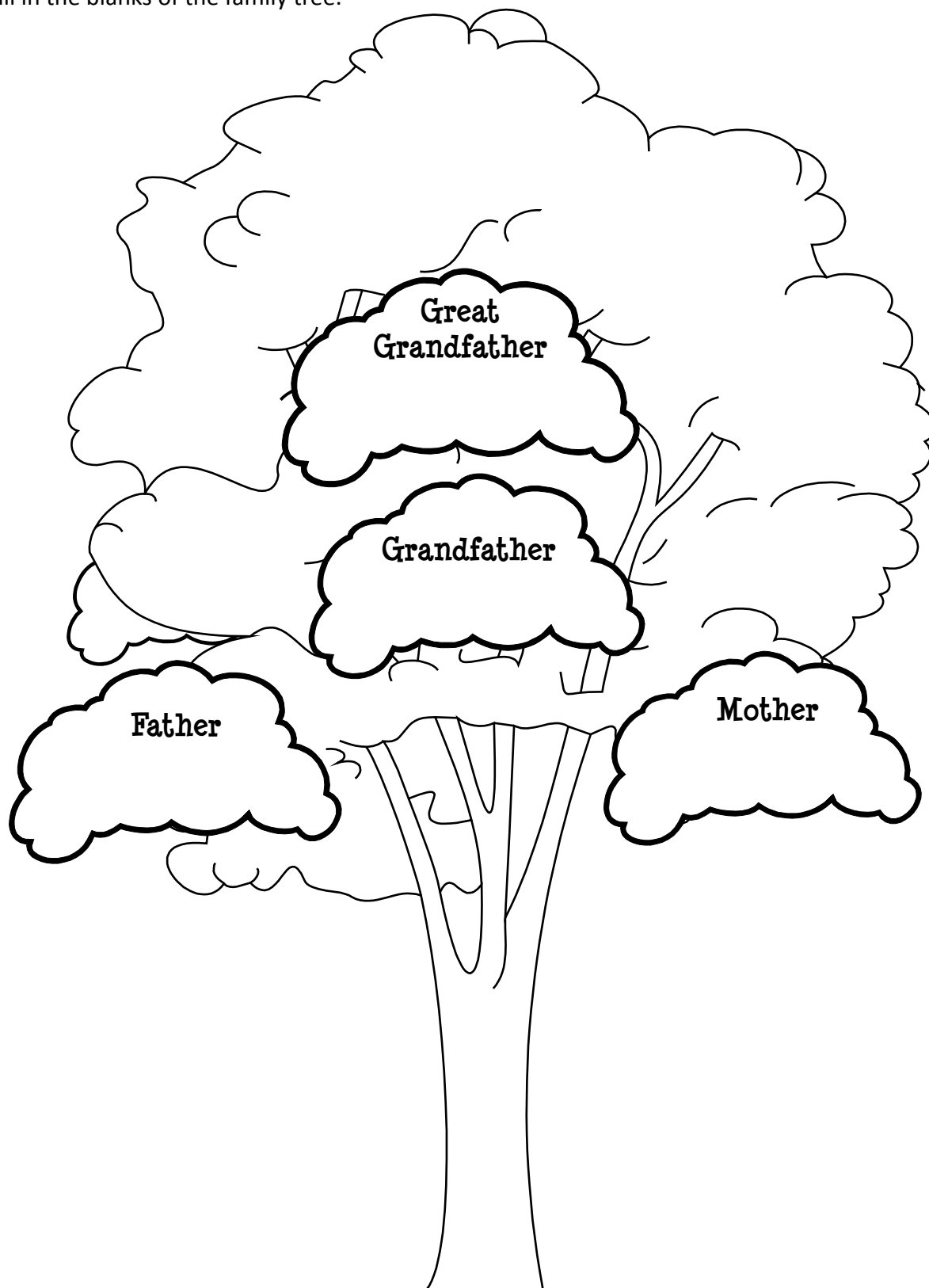

# The spider and it's web

---

Draw a cave around the spider's web which protected the prophet (pbuh) during Hijra (first journey from Makka to Madina).

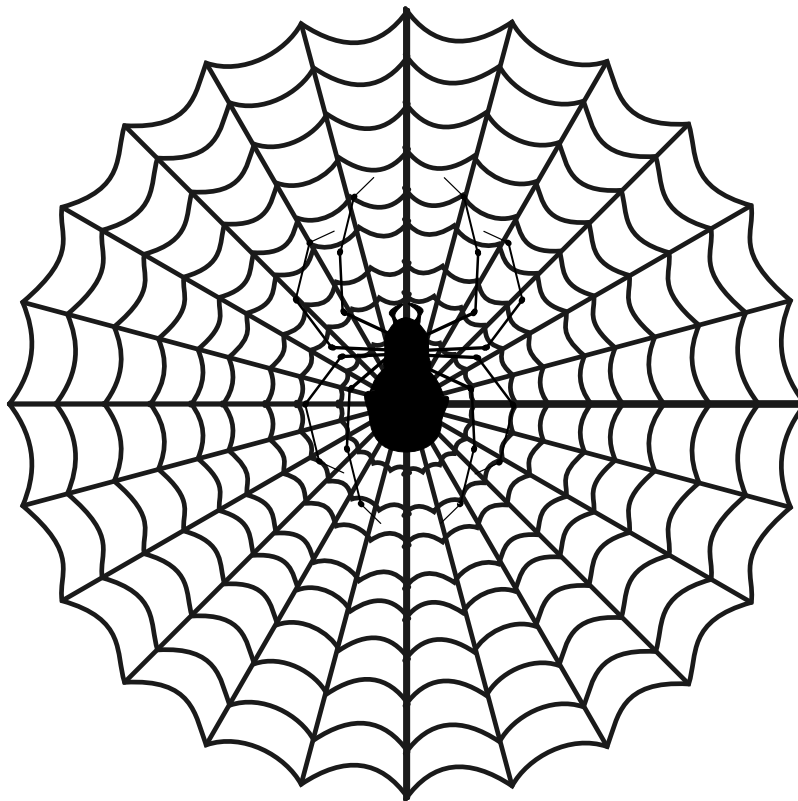

# The Prophet went for Me'raj...

---

When the Prophet went for Me'raj he saw the places of blessings and the places of punishment.

Connect the bad deeds with the place of punishment and the good deeds with the place of blessing.

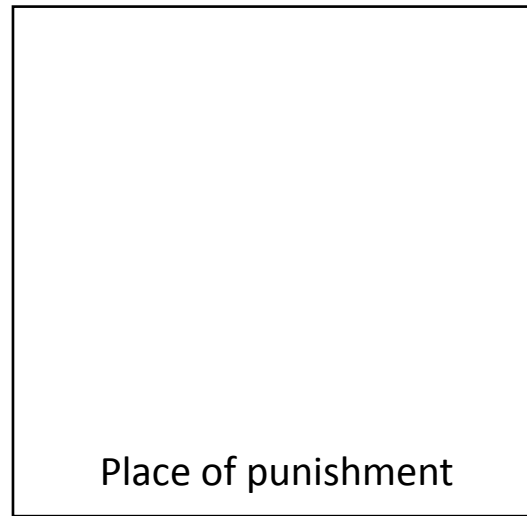
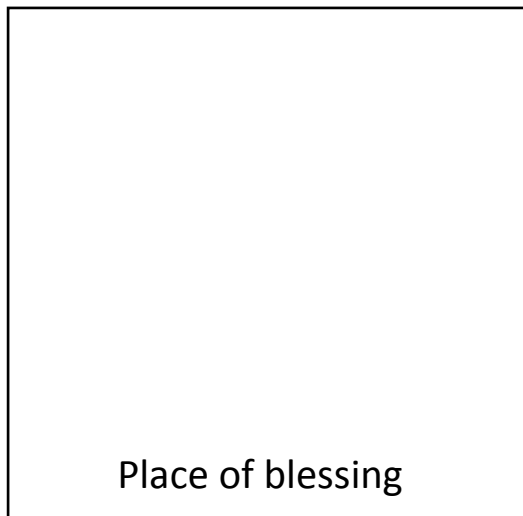

Salaa (Namaz)

Lying

Naughty

Sawm(Fasting)

Reciting Qur'an

Fighting

Being rude

Learning

Doing assignment



# Jigsaw

---

Fill in the missing word to find the name of the perfect person.

ISLA\_

Q\_R'AN

A\_LULBAYT

SAL\_A

EXA\_PLE

\_ADINA

\_LLAH

HA\_ITH



# Family Tree of Bibi Fatima Zahra (pbuh)

---

Fill in the blanks of the family tree.

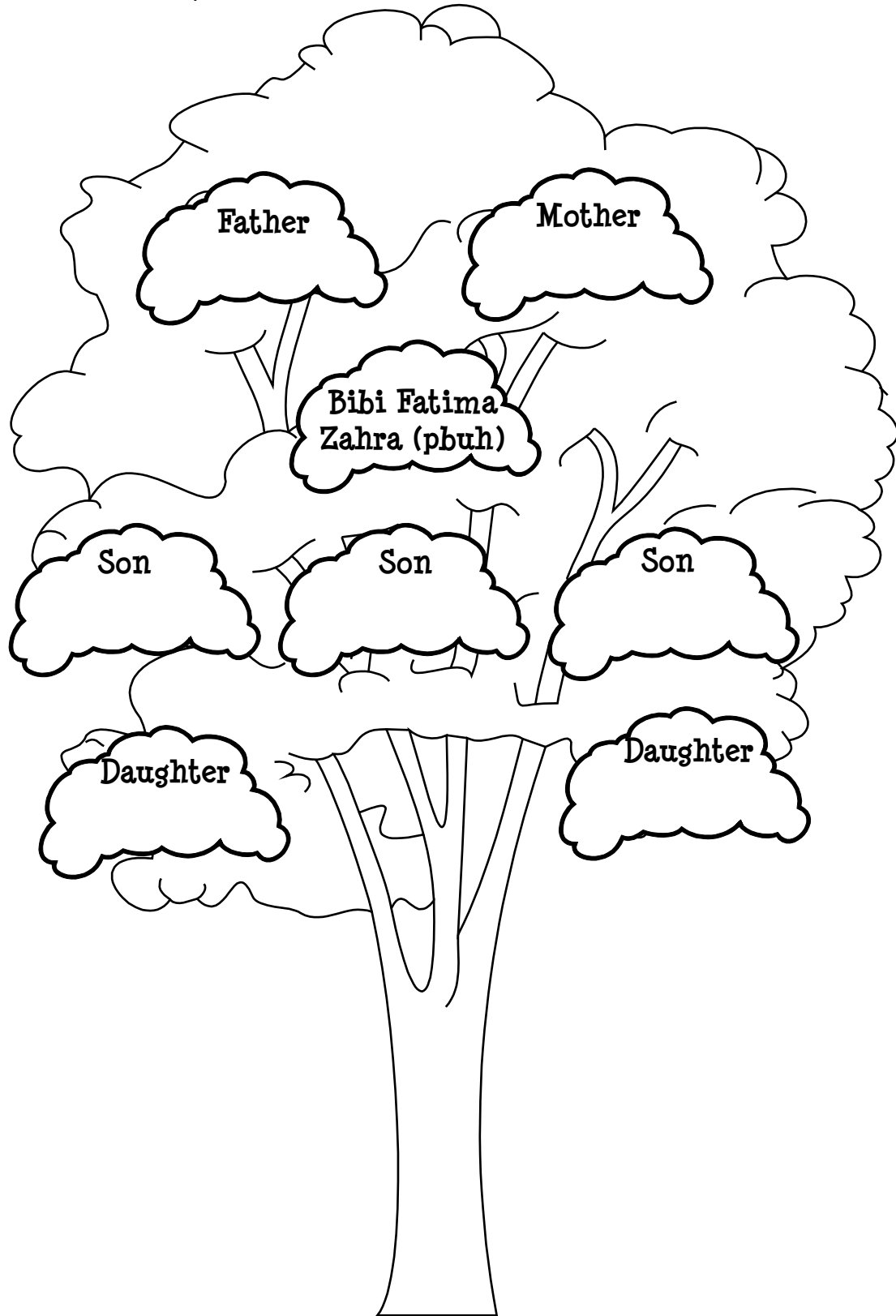

# The Tasbee of Sayyida Fatima Zahra (pbuh)

---

Tasbee of Bibi Fatima Zahra (pbuh)  
Draw 34 beads for 'Allahu Akber'  
33 beads for 'Alhamdulillah'  
33 beads for 'Subhanallah'

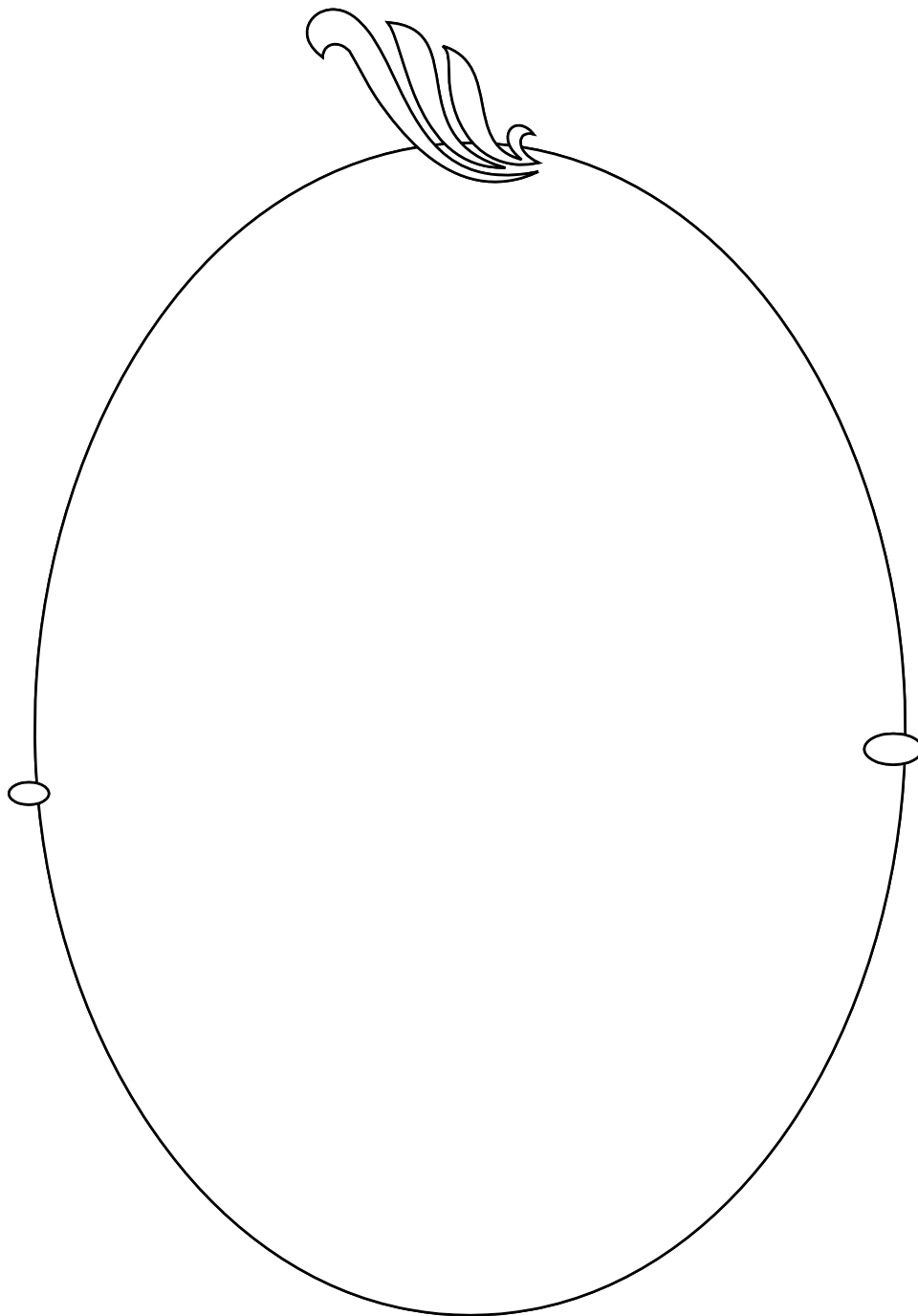



# Wafat of Sayyida Fatim Zahra (pbuh)

---

Join the picture with the event

Baytul Huzn - House built for her by Imam Ali (pbuh) to cry for her father.

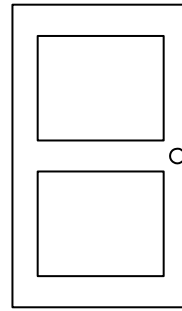

Fadak was taken away from her.

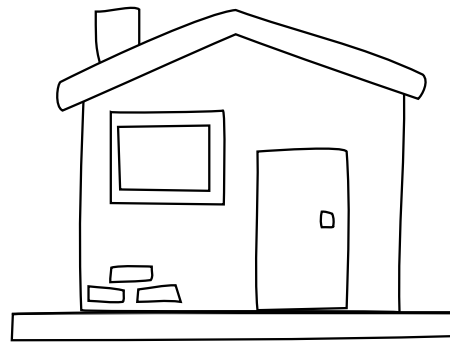

A door was pushed down on Sayyida Fatima (pbuh) Baby Muhsin died.

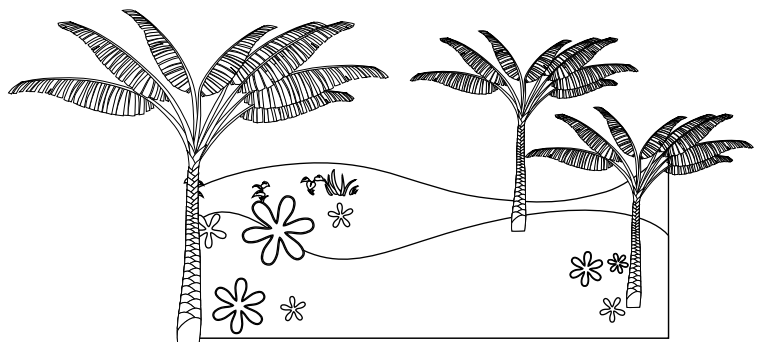

# The Event of the Blanket

---

.....Allah only desires to keep away the uncleanness from you, O people of the House! and to purify you a (thorough) purifying. 33:33

**Her father**

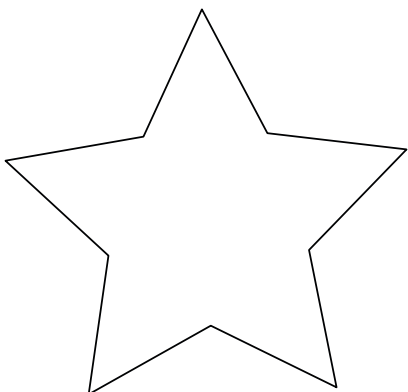

**Her husband**

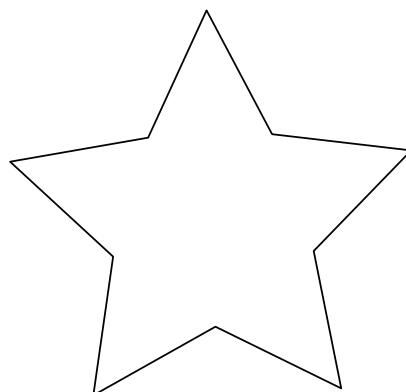

**Fatima (pbuh)**



**Her son**

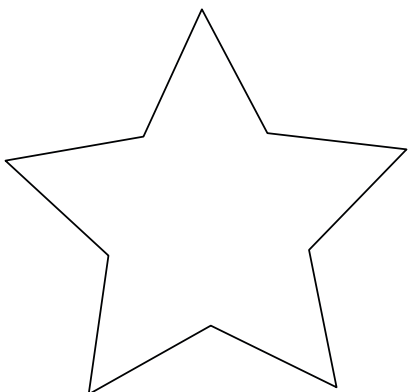

**Her son**

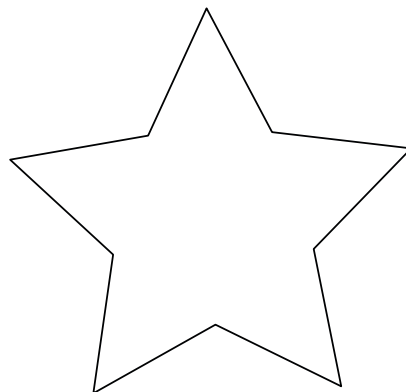

Under the blanket, there were five very special people. In the stars, write the names of the other four people who were with Sayyida Fatima (pbuh).



# Sayyida Fatima Zahra (pbuh)

---

Read the following questions and circle the correct answers

1. Sayyida Fatima (pbuh) was born in \_\_\_\_\_  
a. Makka      b. Madina      c. Karbala      d. Damascus
2. Her father's name was \_\_\_\_\_  
a. Hamza      b. Ja'fer      c. Abu Talib      d. Muhammad
3. Her mother was \_\_\_\_\_  
a. Hajra      b. Halima      c. Amina      d. Khadija
4. When her mother died, Sayyida Fatima (pbuh) was \_\_\_\_\_ years old  
a. 10      b. 8      c. 5      d. 18
5. With the birth of Imam Hasan (pbuh) she became the link between:  
a. Tawheed and Nabuwwa      b. Nabuwwa and Imama  
c. Nabuwwa and Adala      d. Tawheed and Imama
6. Her title Umm Al-Abeeha means:  
a. Radiant      b. Mother of the 11 Imams  
c. Pure      d. Mother of her father
7. Before Fatima (pbuh) was born Allah had assured The Prophet (pbuh) in which sura of the abundance in his progeny that was to be through her.  
a. Nasr      b. Kawthar      c. Takathur      d. Dahr
8. What is Fadak?  
a. 2nd battle of Islam  
b. A Jewish fort  
c. A piece of land given to Sayyida Fatima (pbuh) as a gift  
d. Place where the 1st Khalifa was chosen
9. Sayyida Fatima (pbuh) had \_\_\_\_\_ children.  
a. 3      b. 4      c. 5      d. 6



# Sayyida Fatima (pbuh)

---

Imam Ali (pbuh) about Sayyida Fatima (pbuh) "We lived like two pigeons in a cocoon" Imam Ali (pbuh)

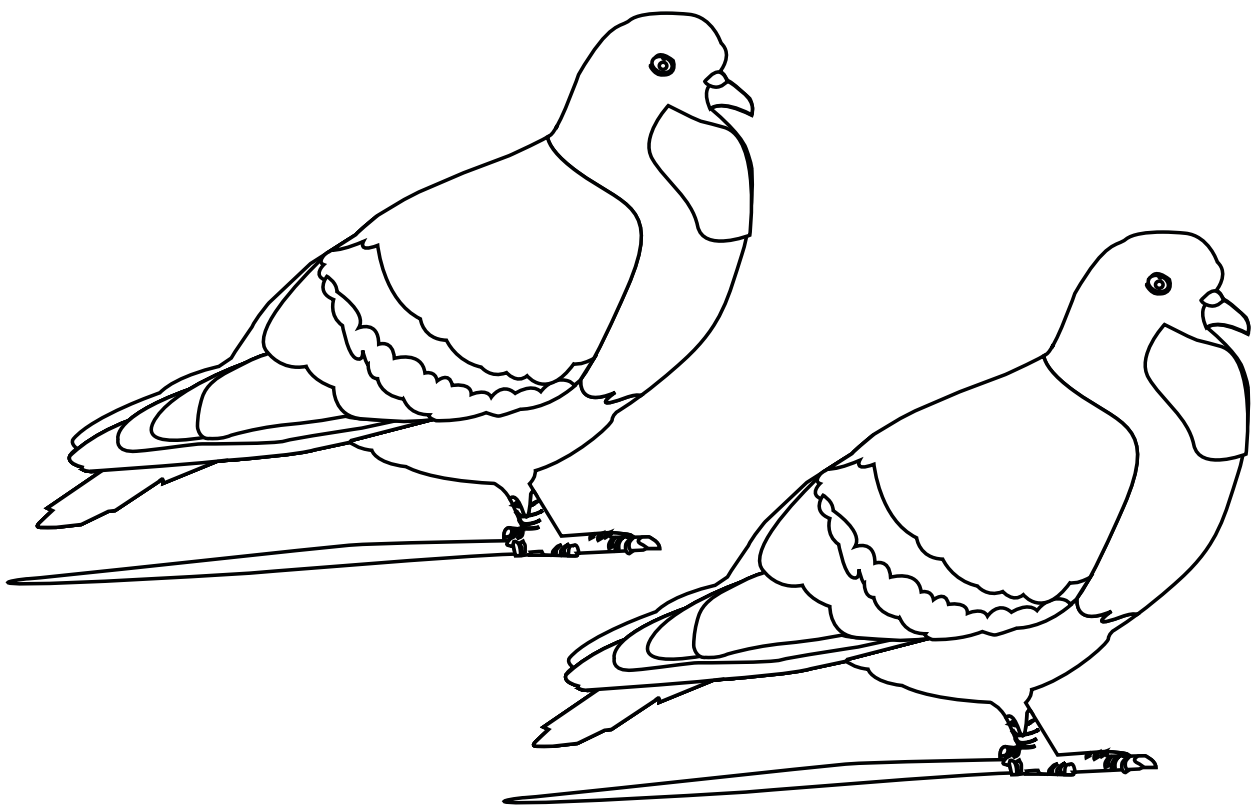

# Sayyida Fatima (pbuh)

“Human kind cannot fully understand Allah except by studying His Attributes (Asma ul Husna)”  
Sayyida Fatima (pbuh)

Find out what each of the above names mean.



Ar-Rahman



Al-Hakeem



Al-Malik



Al-Baseer



Al-Khaaliq



As-Samad



Al-Waduud



# Sayyida Fatima (pbuh)

---

"The Qur'an contains all the knowledge one could want. Following these instructions will lead us to Allah and Heaven." Sayyida Fatima (pbuh)



# Helping others

---

“Allah asks you to be charitable and to help others so that you can get more from Him”  
Sayyida Fatima (pbuh)

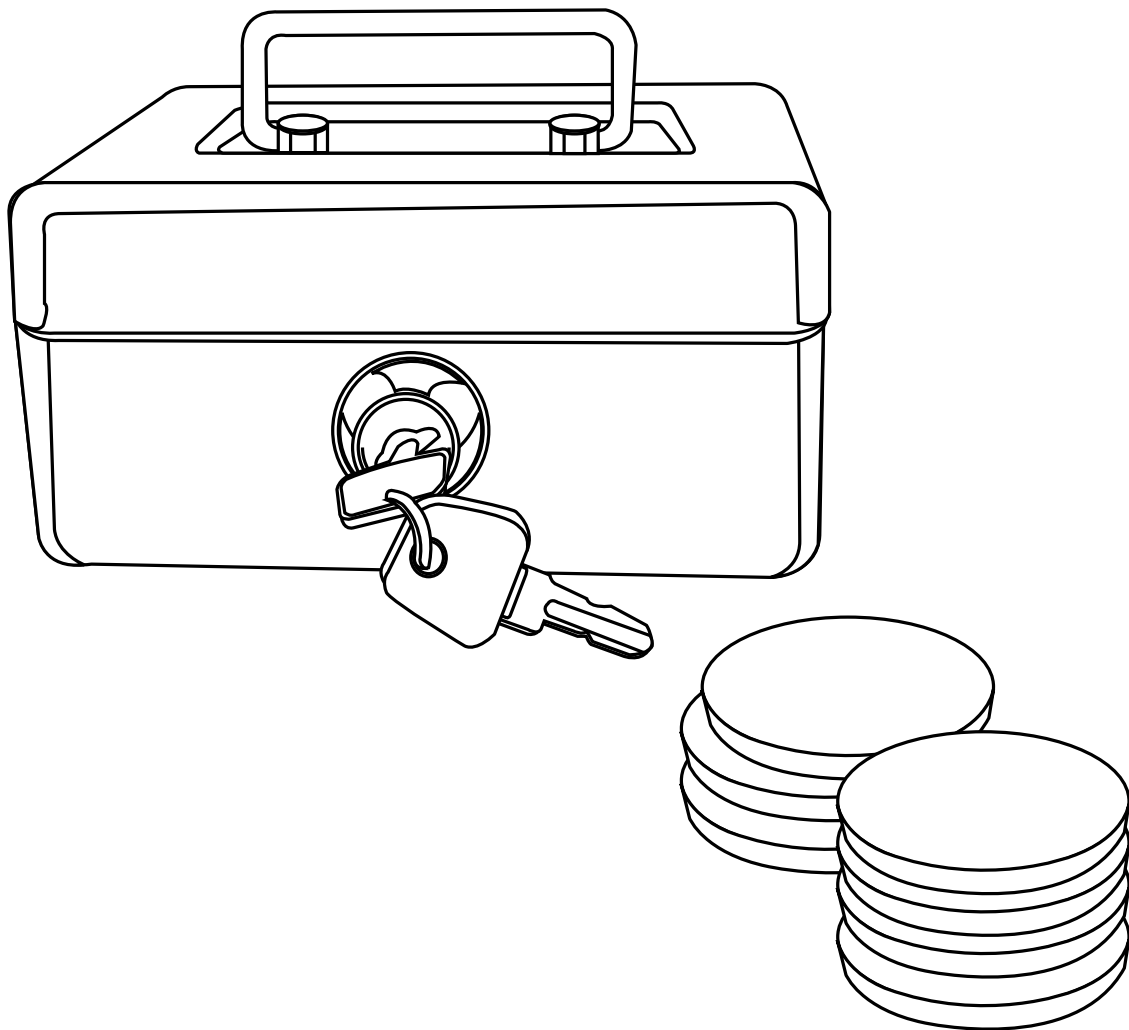

# Be kind to your parents

---

“Allah has advised people to be kind to their parents so that they can avoid displeasing Him.”  
Sayyida Fatima (pbuh)

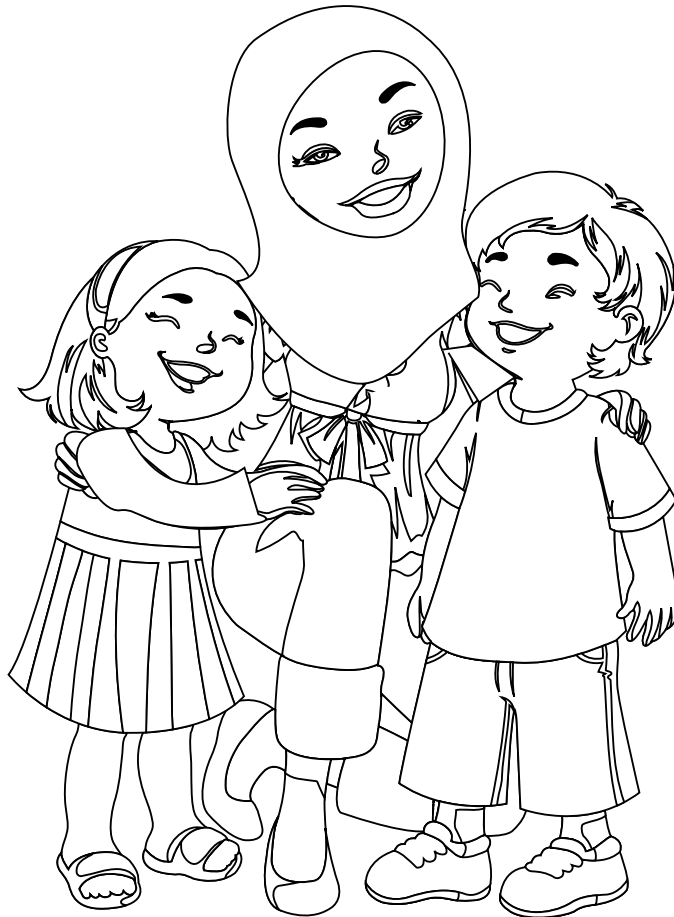

List 5 things that you can do to help your parents:

- 1
- 2
- 3
- 4
- 5





# Imama Quiz

---

Match the columns:



Imam Hasan (pbuh)



Imam Muhammad Taqi (pbuh)



Imam Husayn (pbuh)



Imam Hasan Askery (pbuh)



Imam Ali (pbuh)



Imam Musa Kadhim (pbuh)



Imam Ali Zaynul Abedeen (pbuh)



Imam Ja'fer Sadiq (pbuh)



Imam Muhammad Baqir (pbuh)



Imam Muhammad Mahdi (pbuh)



Imam Ali Ridha (pbuh)



Imam Ali Naqi (pbuh)



# Imama Quiz

---

Match the cups to the teapot:

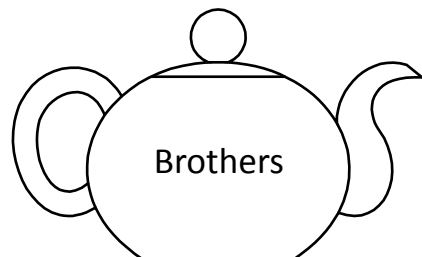
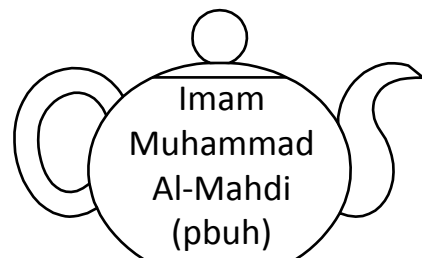
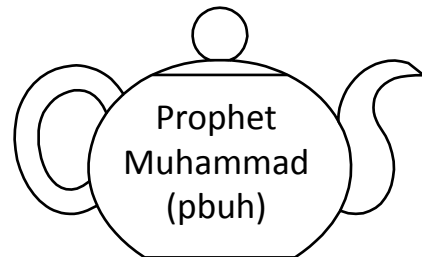
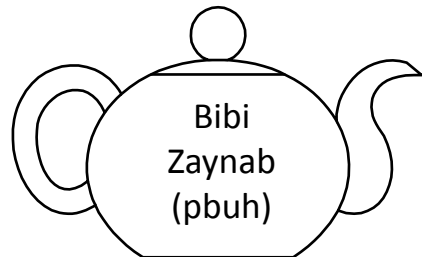
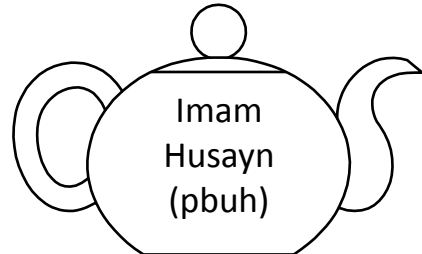
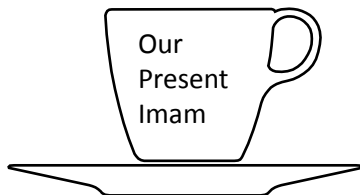
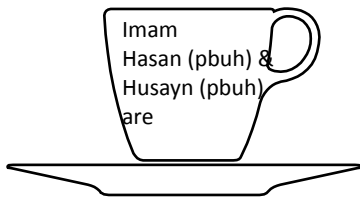
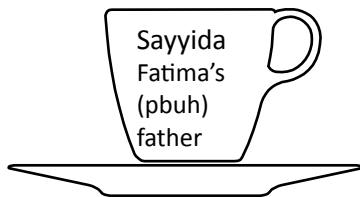
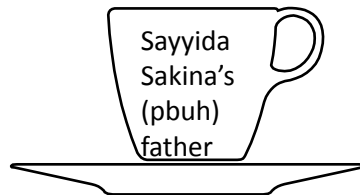
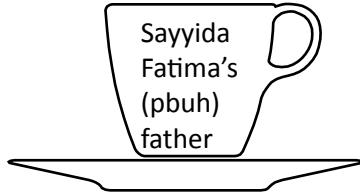

# I Know my Imam...

## My first Imam

---

Full Name: .....

Father's Name: .....

Mother's Name: .....

Date of Birth: .....

Place of Birth: .....

Children and Names: .....

.....

.....

Date of Death: .....

Burial Site: .....

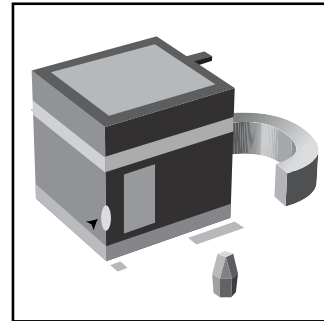

Born in the Ka'ba

One Hadith / Saying:

Another Hadith / Saying:

The Ma'sum who:

\_\_\_\_\_

(write one specific aspect of his life by which you can remember him).



# Family Tree of Imam Ali (pbuh)

Fill in the blanks of the family tree.

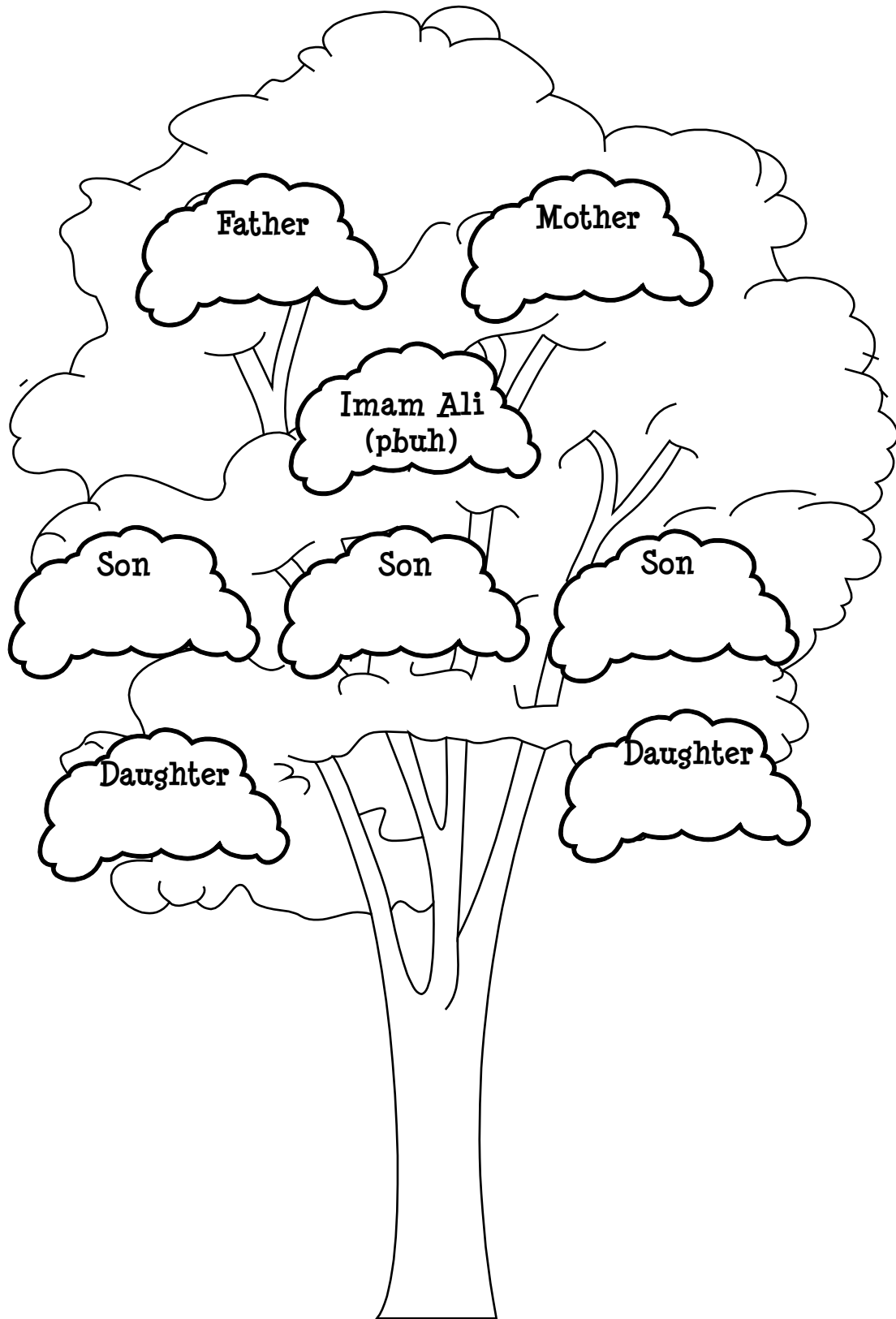

# Activity Sheet - Imam Ali (pbuh)

---

Match the columns

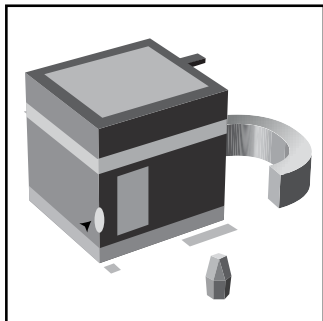

Asadullah which means  
..... of Allah

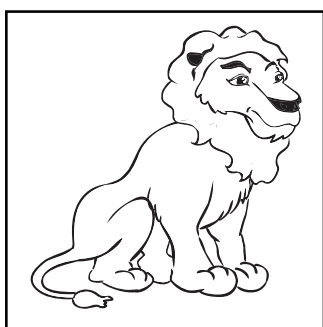

He was born here

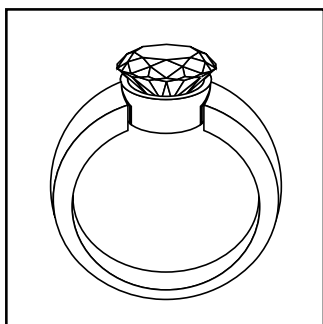

Zulfikar

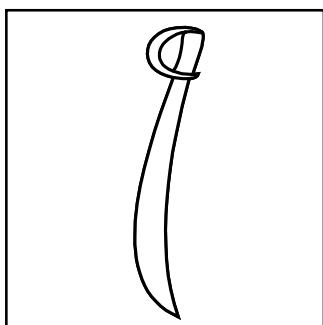

He gave this in ruku  
to a poor man



# I Know my Imam...

## My second Imam

---

Full Name: .....

Father's Name: .....

Mother's Name: .....

Date of Birth: .....

Place of Birth: .....

Children and Names: .....

.....

.....

Date of Death: .....

Burial Site: .....

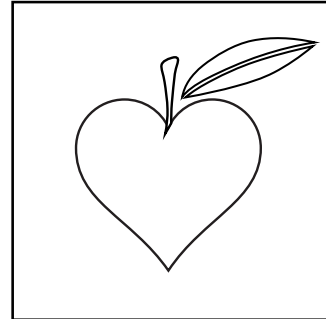

The apple of his  
mother's heart

One Hadith / Saying:

Another Hadith / Saying:

The Ma'sum who:

\_\_\_\_\_

(write one specific aspect of his life by which you can remember him).



# I Know my Imam...

## My third Imam

---

Full Name: .....

Father's Name: .....

Mother's Name: .....

Date of Birth: .....

Place of Birth: .....

Children and Names: .....

.....

.....

Date of Death: .....

Burial Site: .....

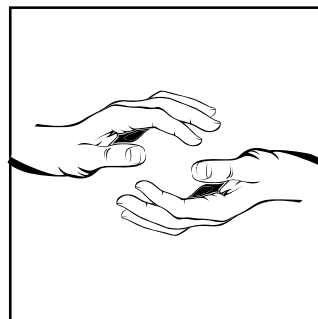

Did not give  
Bay'at to Yazid

\*Bay'at means  
promising to  
follow and obey

One Hadith / Saying:

Another Hadith / Saying:

The Ma'sum who:

\_\_\_\_\_

(write one specific aspect of his life by which you can remember him).



# Imam Husayn (pbuh)

---

Draw a tablet of clay under the boys head.

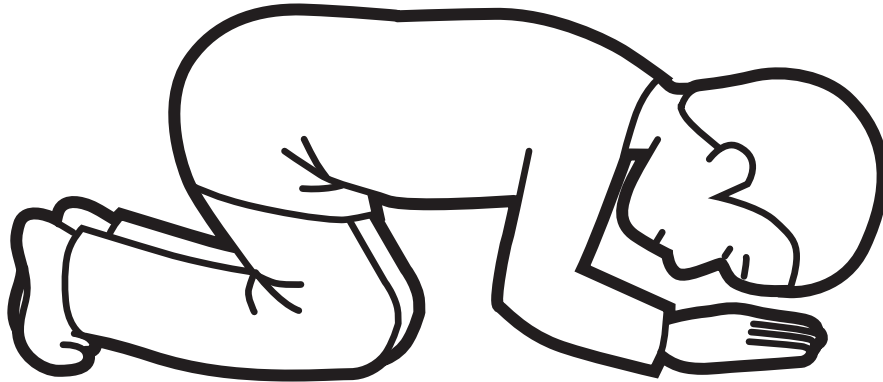

## Khak e Shifa

Find where Kербala is on the map and mark it on the map.





# Imam Husayn (pbuh)

---

“If this world be considered a treasure, then a reward far better is Allah’s pleasure...”  
Imam Husayn (pbuh)

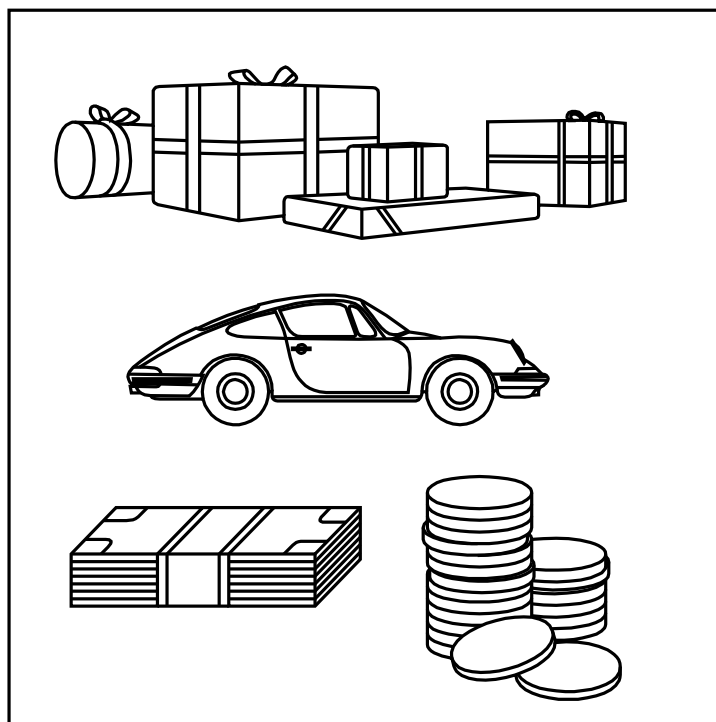

How would you use the things above to get Janna?



# The Candle of Loyalty

---

Imam Husayn (pbuh) blew out a candle on the night of Ashura so that those who wanted to leave could do so. None of his loyal companions left.

Write a list of the companions of Imam Husayn (pbuh) that you know:

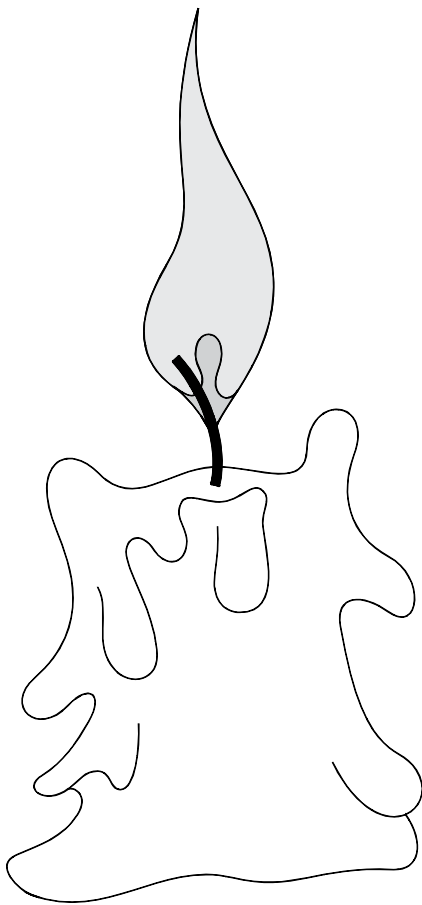

.....

.....

.....

.....

.....

.....

.....

.....

.....

.....

.....

.....

.....

.....

.....

.....

.....

.....

.....

.....

.....

.....



# I Know my Imam...

## My fourth Imam

---

Full Name: .....

Father's Name: .....

Mother's Name: .....

Date of Birth: .....

Place of Birth: .....

Children and Names: .....

.....

.....

Date of Death: .....

Burial Site: .....

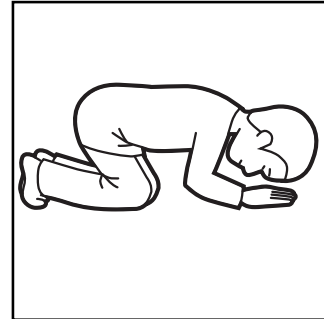

Sayyadus  
Saajideen

One Hadith / Saying:

Another Hadith / Saying:

The Ma'sum who:

\_\_\_\_\_

(write one specific aspect of his life by which you can remember him).



# Imam Zaynul Abideen (pbuh)

---

Match the columns below:

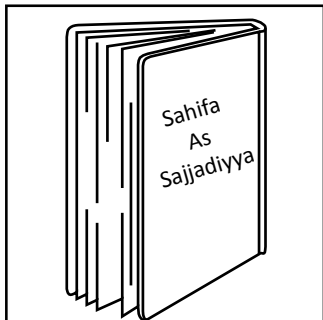

Father

Imam Husayn  
(pbuh)

Mother

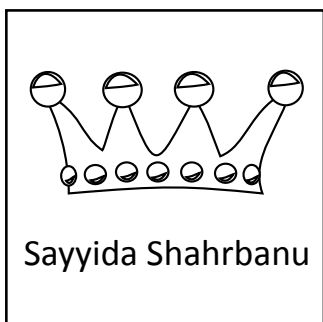

Title

Zaynul Abideen

Book of Duas  
He wrote



# A Letter to My Parents

---

Dear Mum & Dad,

Assalamu Alaykum

I have learnt to say the best or keep quiet so I would like to say the best of words to you today. It is a dua for you from Sahifa As-Sajjadiyya by Imam Ali Zaynul Abedeen(pbuh)

"O Allah!

Thank them for bringing me up,  
Reward them for honouring me,  
And look after them as they looked after me  
when I was little.....

Lots and Lots of Love and Duas



# I Know my Imam...

## My fifth Imam

---

Full Name: .....

Father's Name: .....

Mother's Name: .....

Date of Birth: .....

Place of Birth: .....

Children and Names: .....

.....

.....

Date of Death: .....

Burial Site: .....



Buried in Medina

One Hadith / Saying:

Another Hadith / Saying:

The Ma'sum who:

.....  
(write one specific aspect of his life by which you can remember him).



# Imam Muhammad Al-Baqir (pbuh)

---

Colour the correct batteries which will produce the light of knowledge.

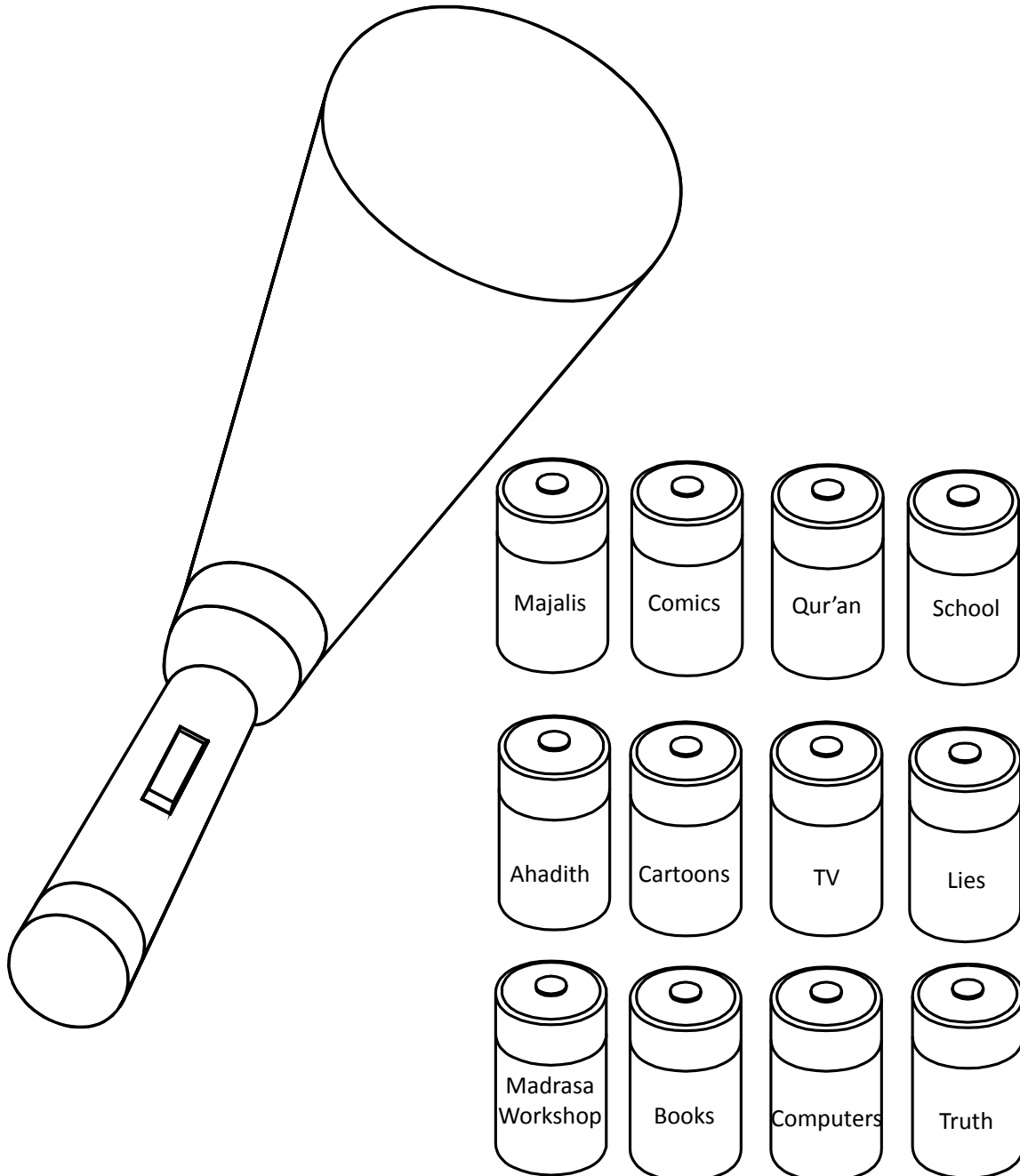

# I Know my Imam...

## My sixth Imam

---

Full Name: .....

Father's Name: .....

Mother's Name: .....

Date of Birth: .....

Place of Birth: .....

Children and Names: .....

.....

.....

Date of Death: .....

Burial Site: .....

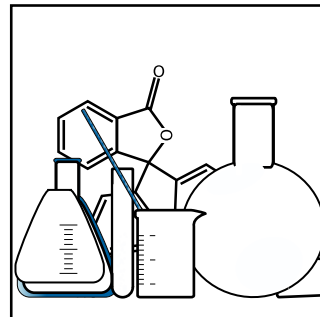

Teacher of  
Chemistry

One Hadith / Saying:

Another Hadith / Saying:

The Ma'sum who:

.....  
(write one specific aspect of his life by which you can remember him).





# Imam Ja'fer As-Sadiq (pbuh)

---

Jabir Ibn Hayyan (known as Geber) who is the Father of Chemistry learnt from Imam Ja'fer As-Sadiq (pbuh)

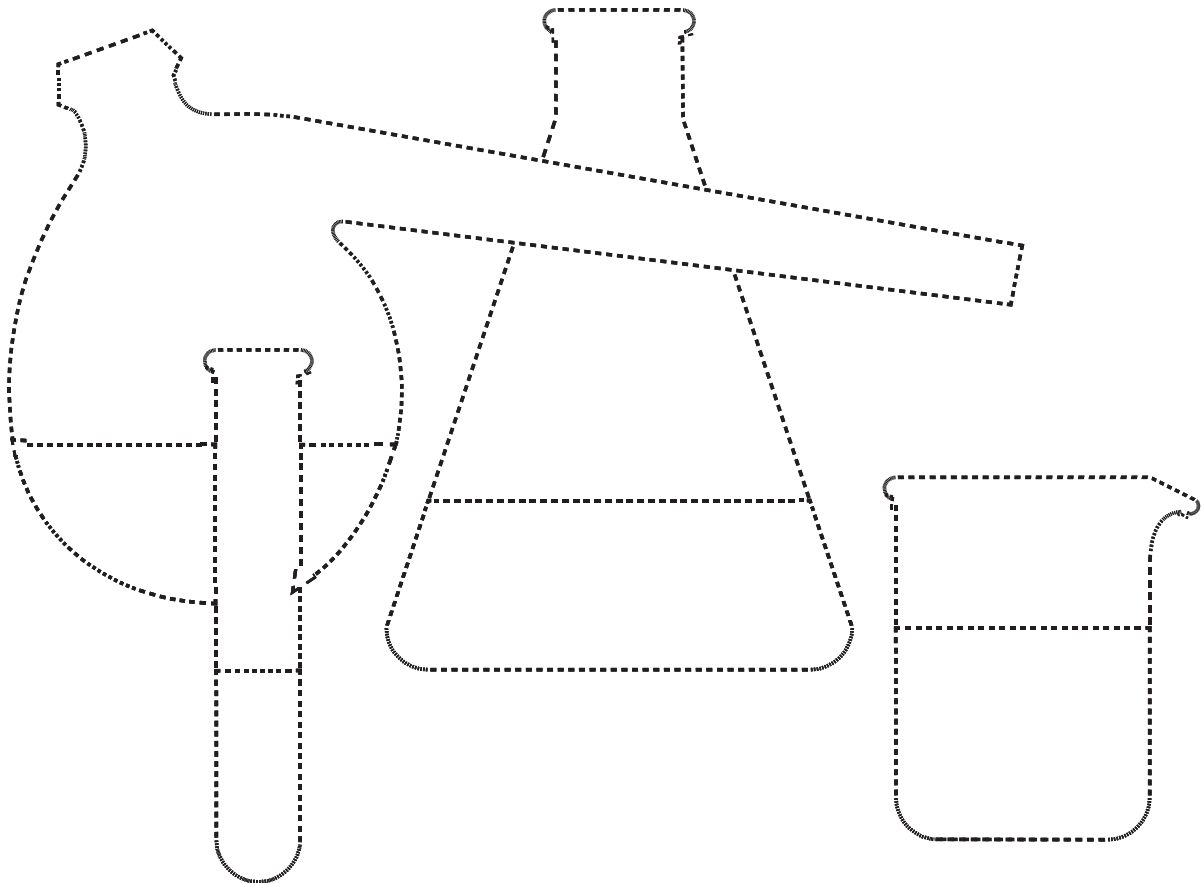

Join the dots and colour the picture



# Imam Ja'fer As-Sadiq (pbuh)

---

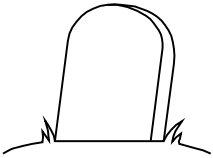
Match the columns below:

Number of students taught by Imam	His Father
 He is Buried here	Jabir Ibn Hayyan
Imam Muhammed Al- Baqir (pbuh)	Mother
 Student & Companion of Imam Father of Chemistry	Mansur
 Poisoned him with grapes	4000
Umme Farwa	Jannatul Baqee



# I Know my Imam...

## My seventh Imam

---

Full Name: .....

Father's Name: .....

Mother's Name: .....

Date of Birth: .....

Place of Birth: .....

Children and Names: .....

.....

.....

Date of Death: .....

Burial Site: .....



Kadhmayn is the suburb of Baghdad

One Hadith / Saying:

Another Hadith / Saying:

The Ma'sum who:

\_\_\_\_\_

(write one specific aspect of his life by which you can remember him).



# Imam Musa Al-Kadhim (pbuh)

---

He is our 7th Imam born on the 7th of Safar so we celebrate his wiladat on the 7th of the 7th month.

Join the dots to find the name of the 7th month.

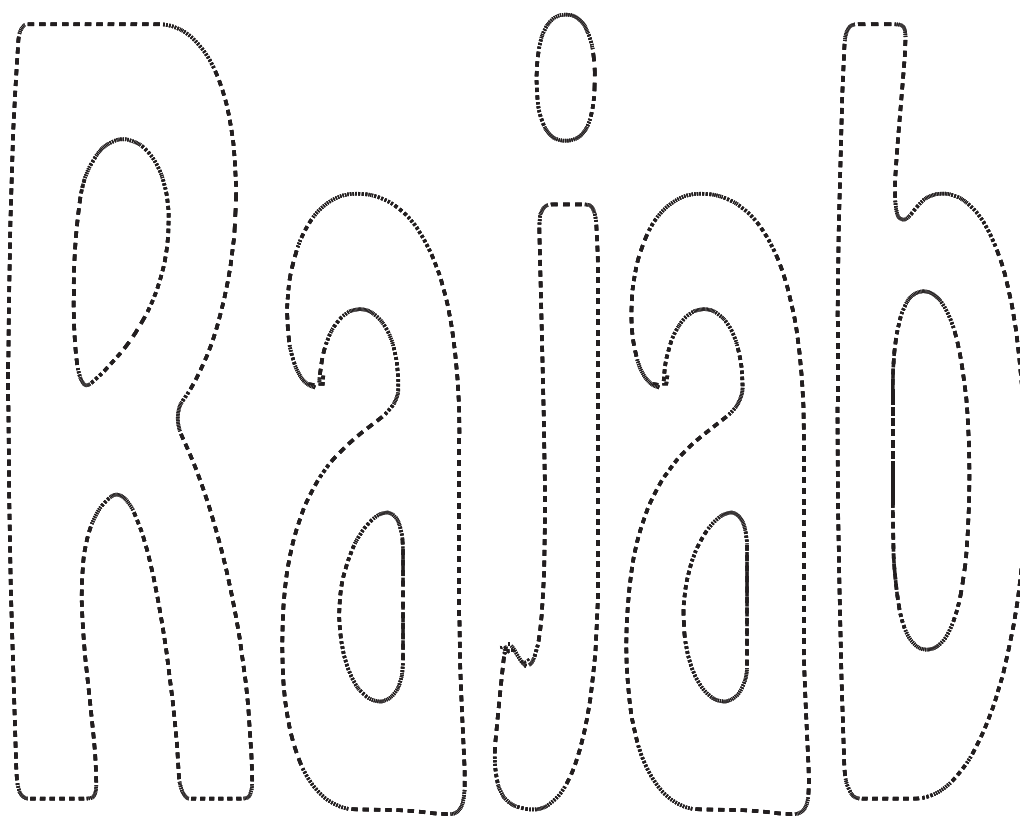

# Al-Kadhim

## The one who swallows anger

---

Draw a cross on the one who is angry.



Draw a happy face and an angry face in the circles below.

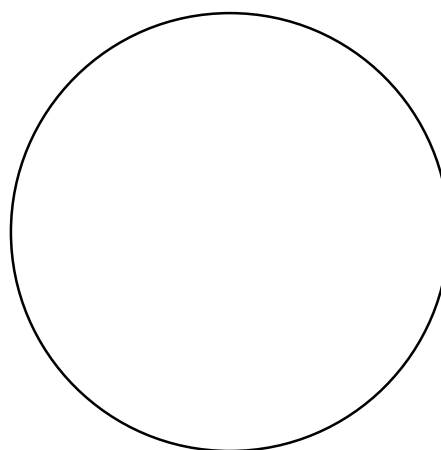
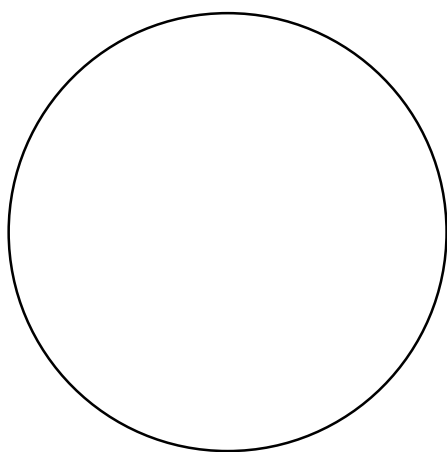

# I Know my Imam...

## My eighth Imam

---

Full Name: .....

Father's Name: .....

Mother's Name: .....

Date of Birth: .....

Place of Birth: .....

Children and Names: .....

.....

.....

Date of Death: .....

Burial Site: .....

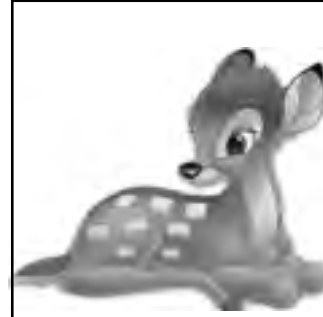

The deer is saved  
by Imam Zaamin

One Hadith / Saying:

Another Hadith / Saying:

The Ma'sum who:

\_\_\_\_\_

(write one specific aspect of his life by which you can remember him).



# Hadith of the golden chain

---

Write the names of the Prophet (pbuh) and Aemma upto Imam Ridha (pbuh) preferably with gold glitter on strips of paper.

Make a paper chain and connect it to some wings with Jibraeel written on them and then to a circle with Allah on it.

Connect the bottom of the chain to a FORT with Laa Ilaha Illallah written on it.

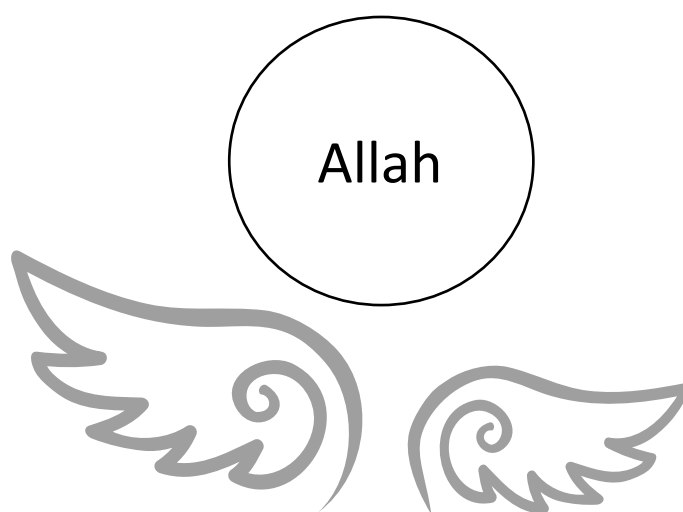

Jibraail

Name of Ma'sum



# Poem - Imam Ali Ridha (pbuh)

---

To the hunter with the deer,  
Said my Imam "Have no fear",

"Let her feed her kids,  
She'll return to you after seeing to their needs",

"I'll stand in her place,  
I promise you'll not lose face",

The deer returned as promised by Imam,  
Safely to the hunter who became calm.

Imam is the surety  
To ward off calamity.

Colour in the picture below

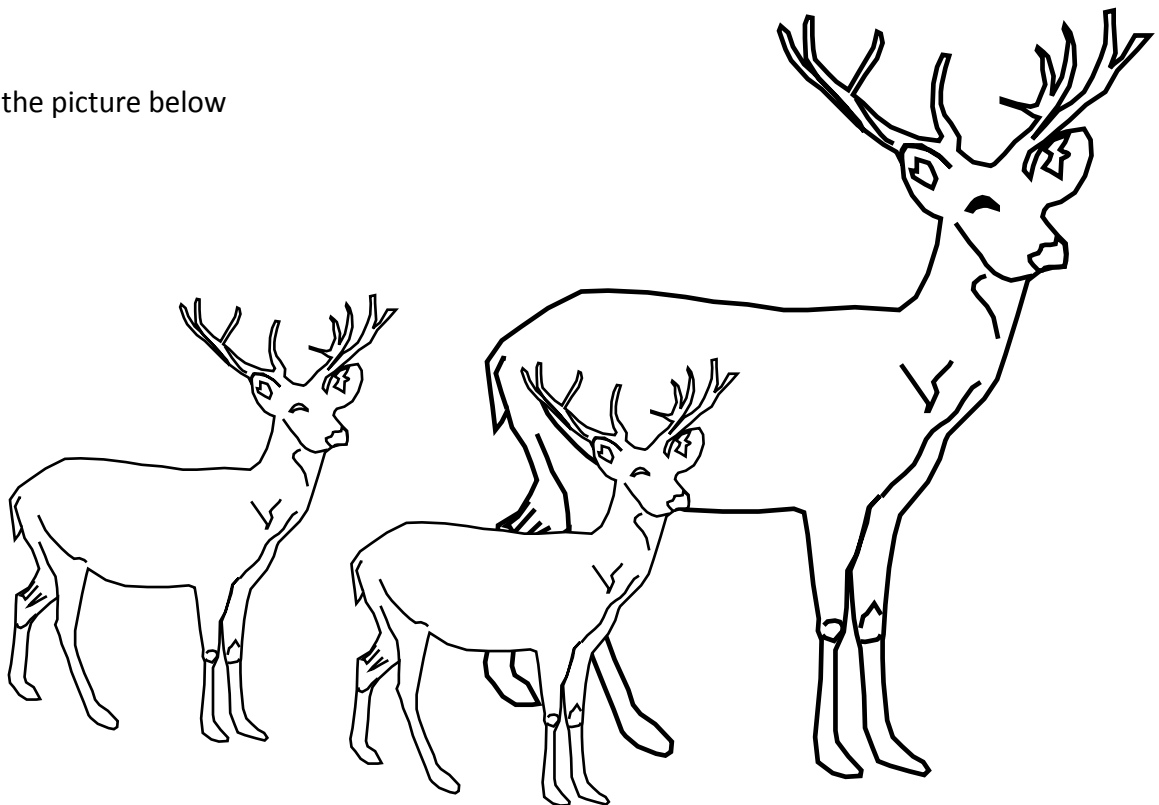



# I Know my Imam...

## My ninth Imam

---

Full Name: .....

Father's Name: .....

Mother's Name: .....

Date of Birth: .....

Place of Birth: .....

Children and Names: .....

.....

.....

Date of Death: .....

Burial Site: .....

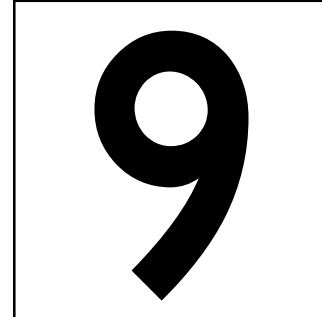

Became Imam  
at the age of 9

One Hadith / Saying:

Another Hadith / Saying:

The Ma'sum who:

\_\_\_\_\_

(write one specific aspect of his life by which you can remember him).



# Imam Muhammad At-Taqi (pbuh)

---

From the story in your manual - what did Ma'mun have in his hands?

Join the dots and colour the picture.

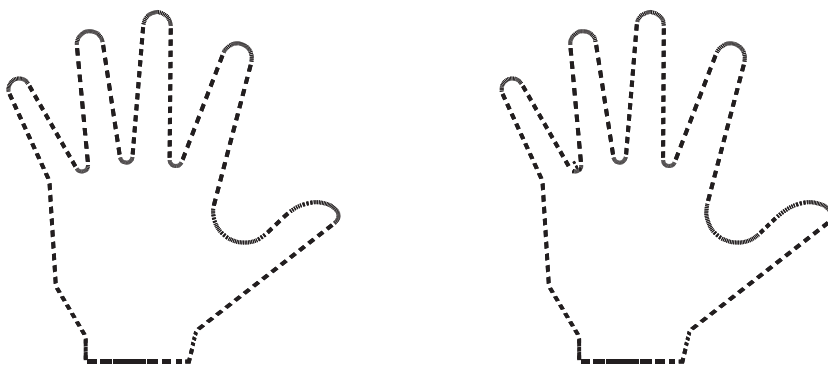
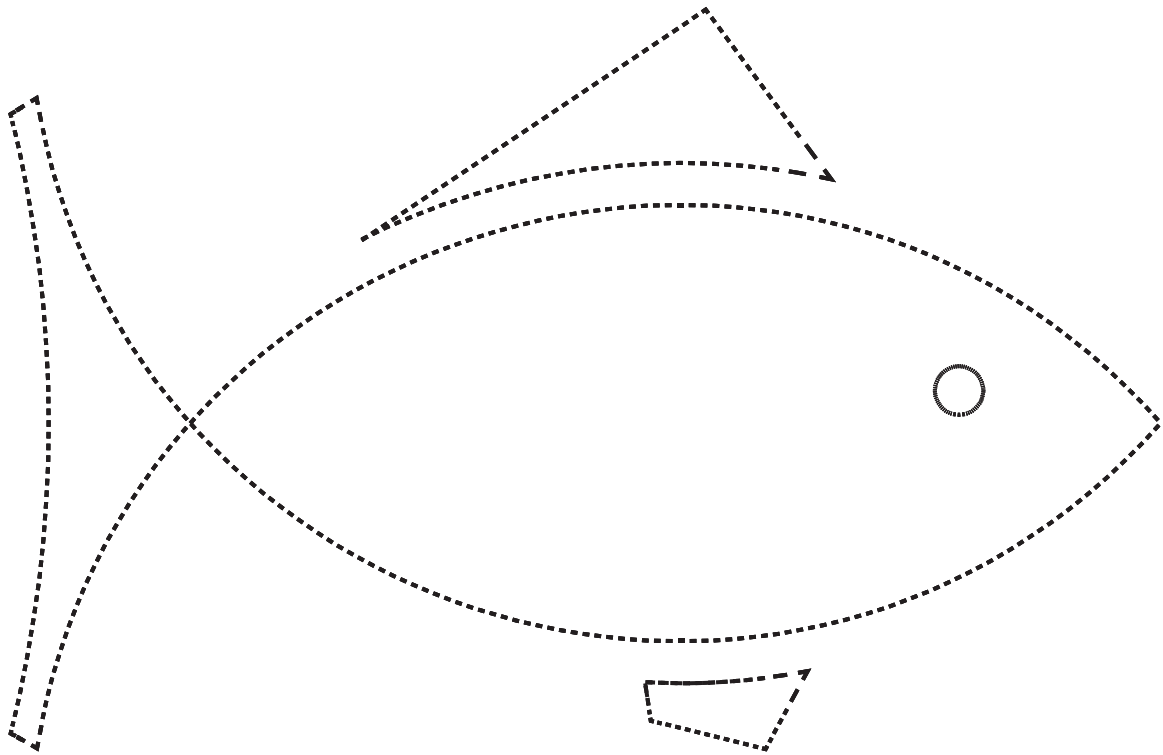

# I Know my Imam...

## My tenth Imam

---

Full Name: .....

Father's Name: .....

Mother's Name: .....

Date of Birth: .....

Place of Birth: .....

Children and Names: .....

.....

.....

Date of Death: .....

Burial Site: .....

Al-Haadi  
The Guide

One Hadith / Saying:

Another Hadith / Saying:

The Ma'sum who:

\_\_\_\_\_

(write one specific aspect of his life by which you can remember him).



# The shrine of Imam Ali Naqi (pbuh) in Samarra

---

Colour the shrine below.

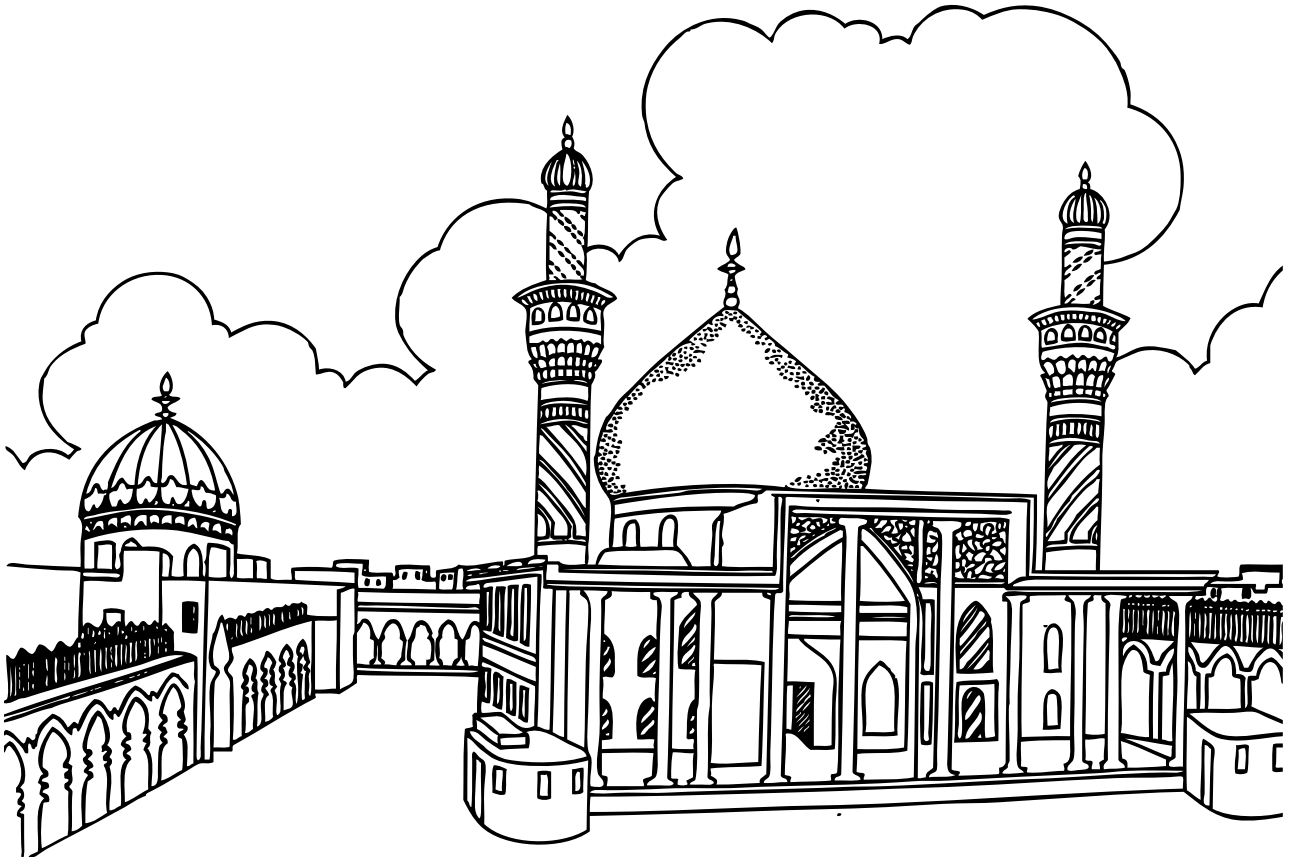

# I Know my Imam...

## My eleventh Imam

---

Full Name: .....

Father's Name: .....

Mother's Name: .....

Date of Birth: .....

Place of Birth: .....

Children and Names: .....

.....

.....

Date of Death: .....

Burial Site: .....

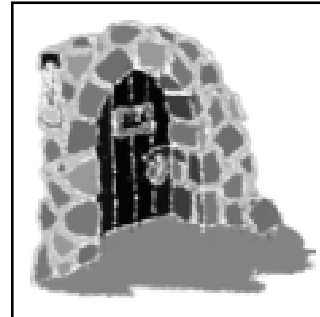

Was imprisoned  
most of his life

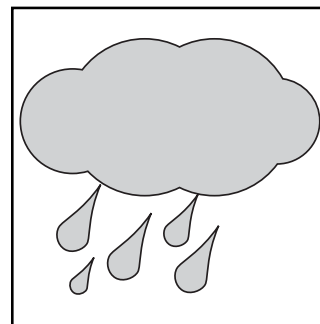

Prayed for rain

One Hadith / Saying:

Another Hadith / Saying:

The Ma'sum who:

\_\_\_\_\_

(write one specific aspect of his life by which you can remember him).



# The signs of a Mu'min

## Imam Hasan Askery (pbuh)

---

Colour the pictures below

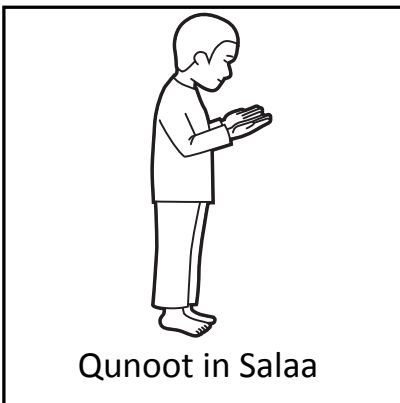
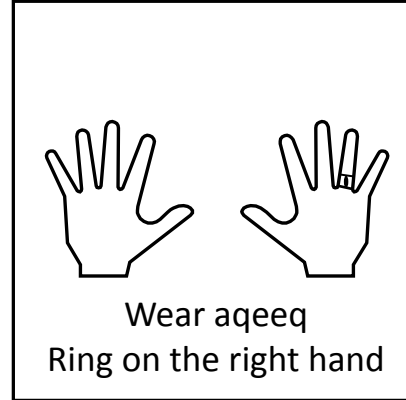
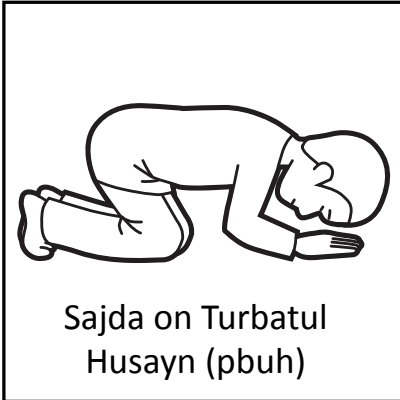

# Imam Hasan (pbuh)

---

Fold a piece of card and draw a heart on the front cover.  
Write Imam Hasan (pbuh) on it. Colour and decorate the heart.

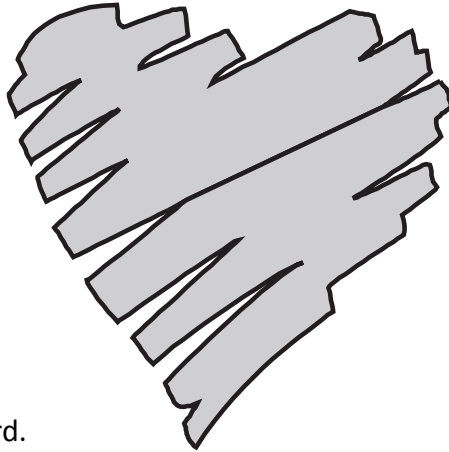

Write a greeting inside the card.  
e.g.

In Hadithe Kisaa, Sayyida  
Fatima Zahra (pbuh)  
addressed her son Imam  
Hasan (pbuh) as “Thamarata  
fuaadiy” - Dlight of my heart

To,  
My dearest Mummy & Papa,

On this day I promise that I  
Will try my best to follow the  
teachings of my Imam and I  
hope always to remain your  
thamarata fuaadiy.

Lots & Lots of Love & Duas



# I Know my Imam...

## My present Imam

---

Full Name: .....

Father's Name: .....

Mother's Name: .....

Date of Birth: .....

Place of Birth: .....

Children and Names: .....

.....

.....

Date of Death: .....

Burial Site: .....



One who guides  
even though we  
cannot see him

One Hadith / Saying:

Another Hadith / Saying:

The Ma'sum who:

\_\_\_\_\_

(write one specific aspect of his life by which you can remember him).





# Imam Zamana (pbuh)

---

Put the first letter of each picture into the adjacent box to find one of the titles of Imam.

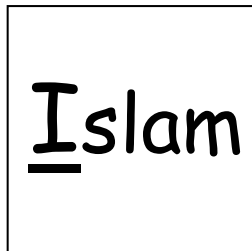
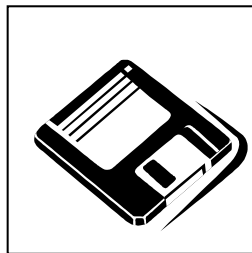
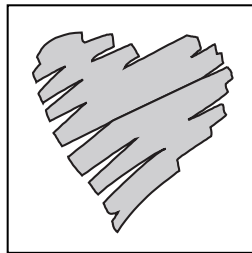
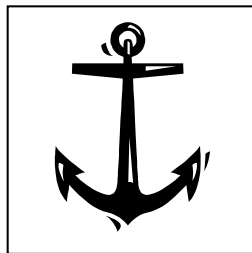
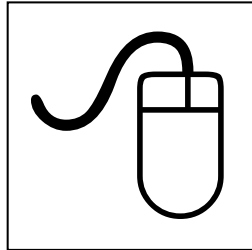

# Imam

Imam means Leader

Circle all the things you would do as a follower for your Imam -  
Imam Muhammad Al-Mahdi (pbuh)

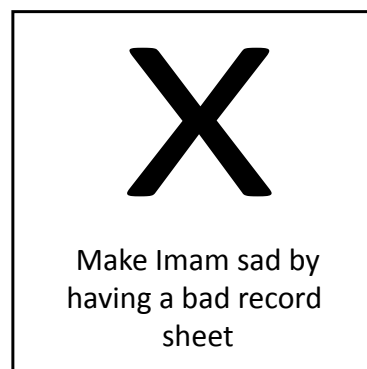
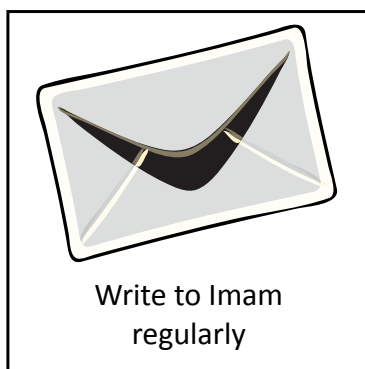
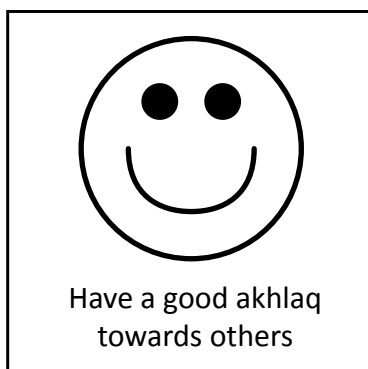
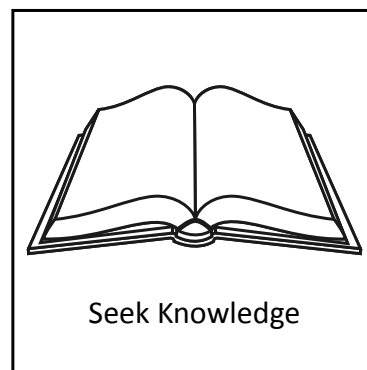
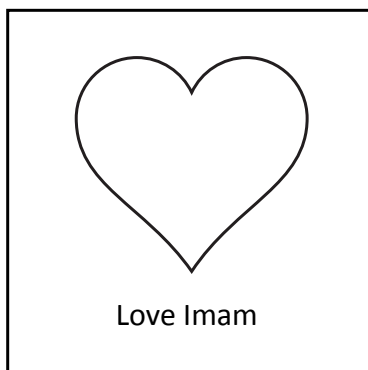
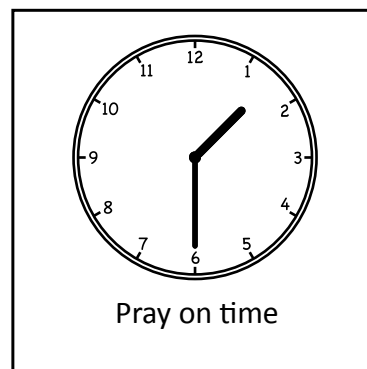
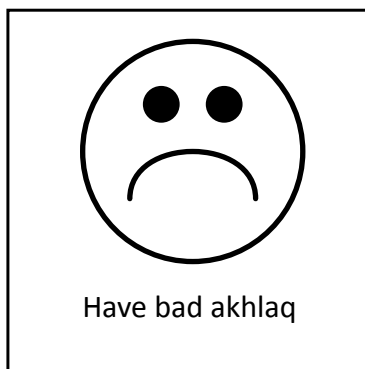
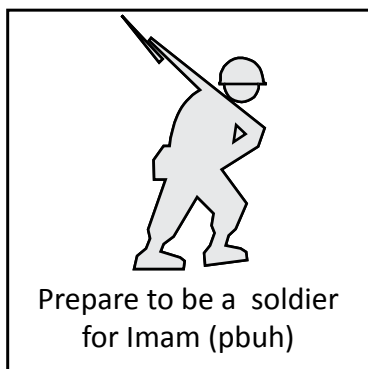

# Imam Muhammad Al-Mahdi (pbuh)

---

How old is Imam Muhammad Al-Mahdi (pbuh) this year?

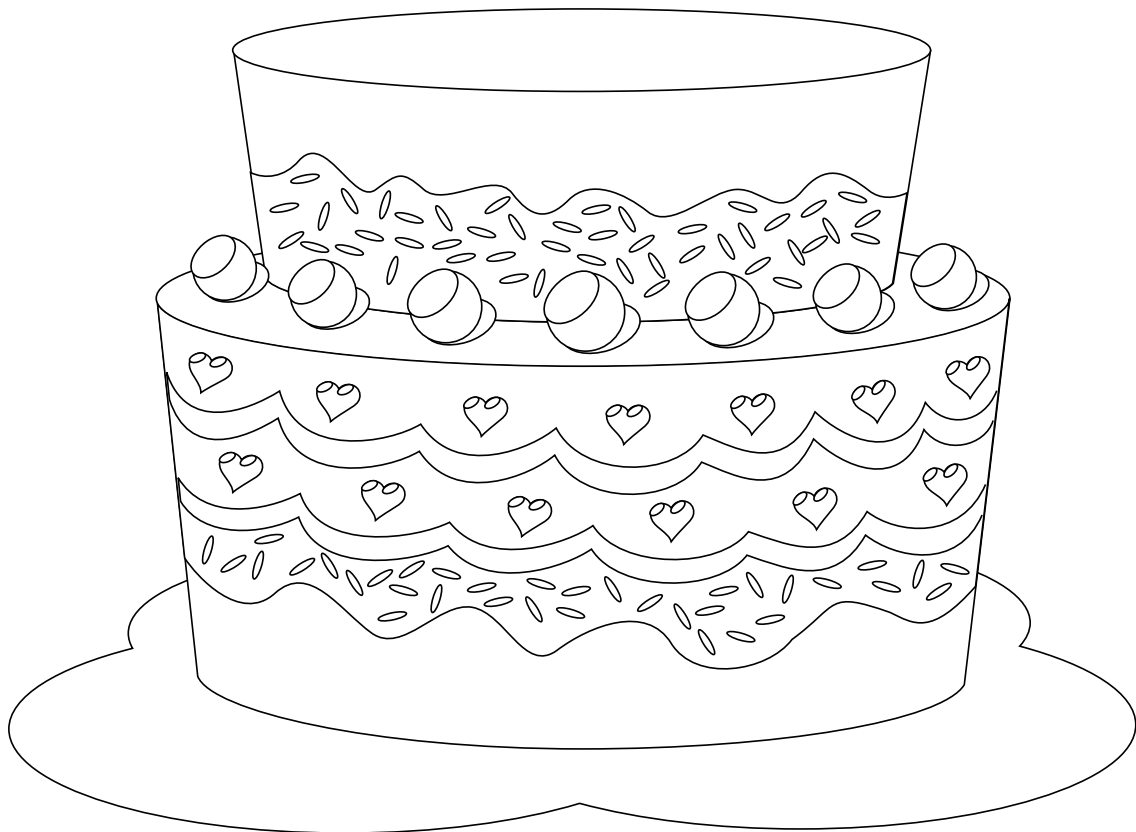

Imam was born on the 15th Shaban 255 A.H.

The date today is .....

Imam is ..... years old.



# Tawba - Seeking Forgiveness from God

---



Correct the wrong



If you've hurt someone,  
say sorry  
If you've taken something,  
return it



Promise to try your best not to do it again

Write down 10 that you seek forgiveness from God?

---

---

---

---



# Calendar

---

Fold an A4 sheet of paper length wise in half.

Mark the ISLAMIC months on the paper and decorate.

Cut a piece of card 5" x 2".

Make two cuts on the card half an inch from the top and bottom as shown below by the dotted lines.

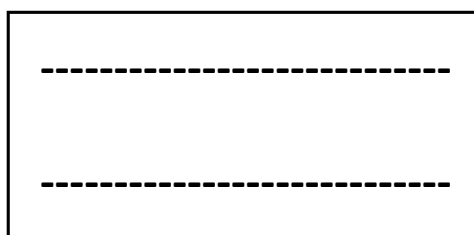

Slide the folded A4 paper with the months through the cuts in the card.



# Comparison of Lunar/Solar Calendar

Draw two concentric circles.

Mark the Lunar (Islamic) months in the outer circle.

Mark the Solar (Gregorian) months in the inner circle.

in the circle through the middle.

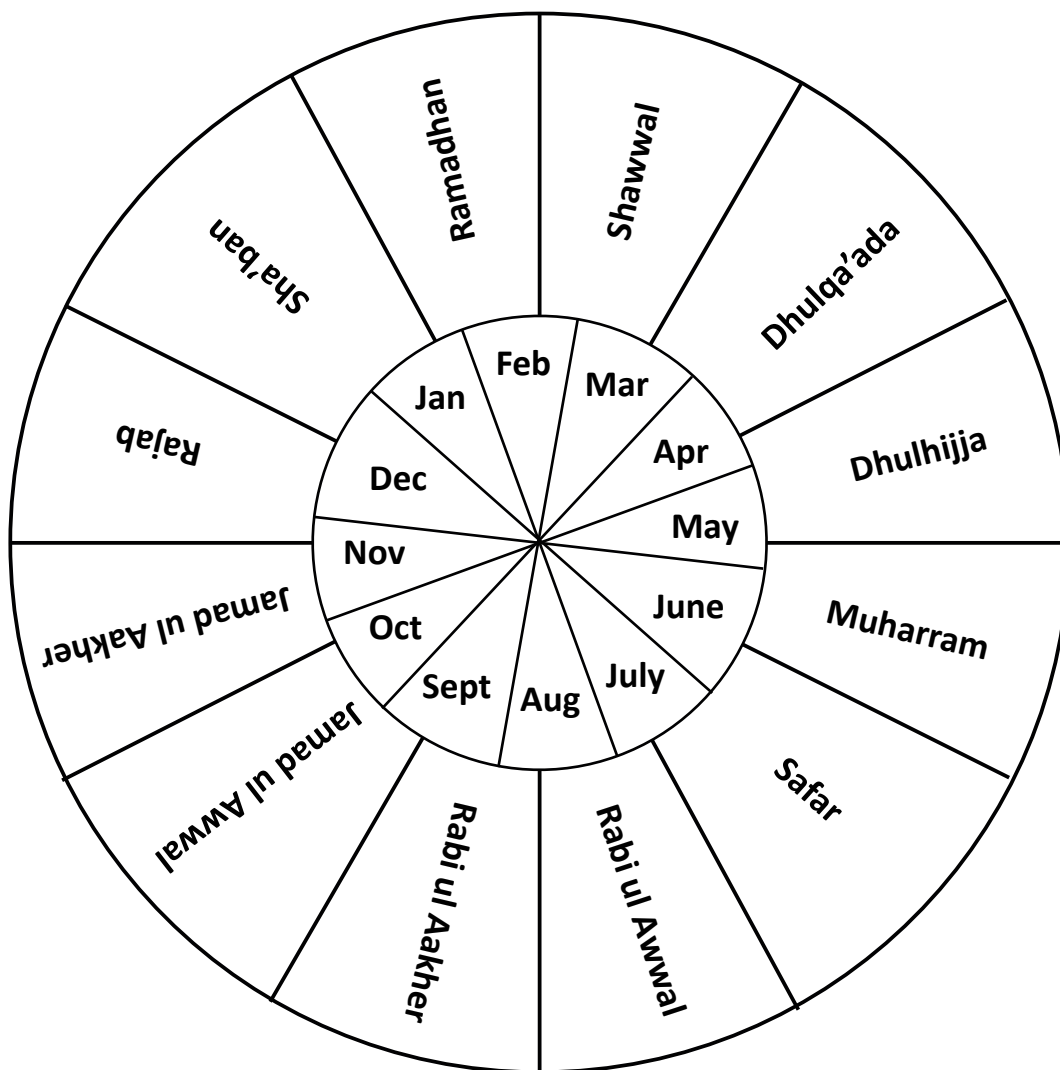

# The Sun And The Moon

---

Draw the sun and the moon side by side on a piece of paper. Colour the sun yellow or if possible sprinkle on gold glitter.

Stick foil on the moon shape.

Fold the paper (like a card) and see how the brilliance of the sun can be seen as a reflection on the moon.

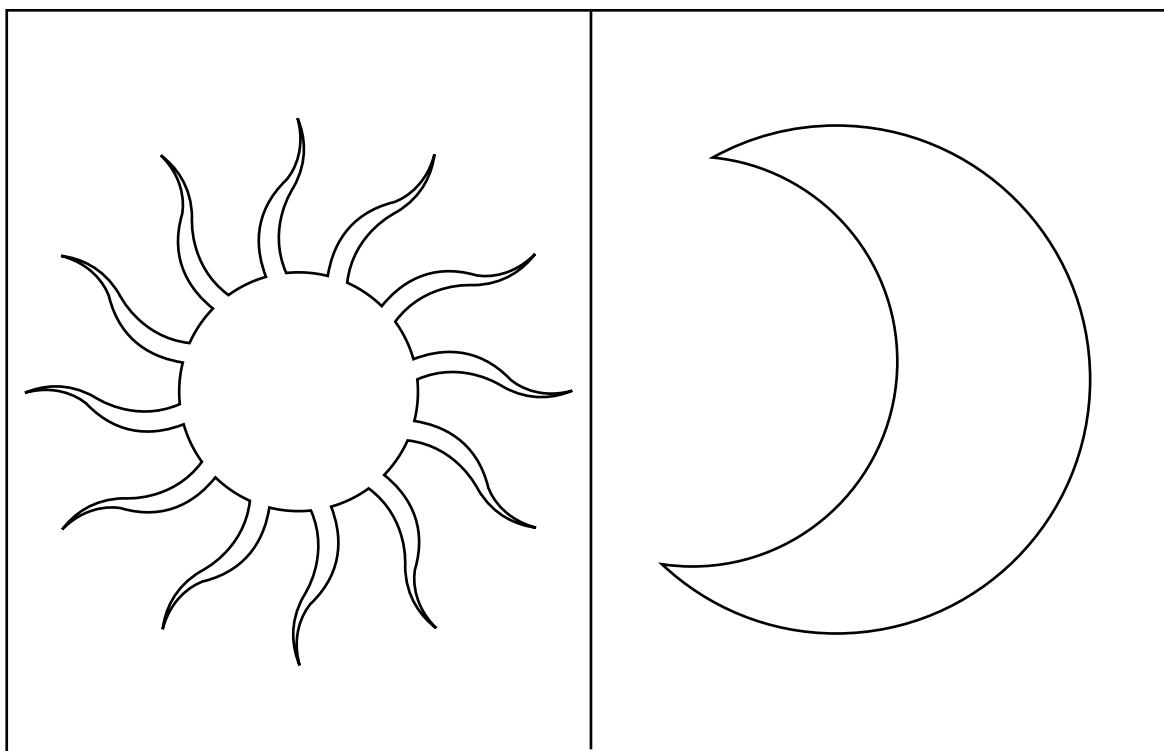

# Thawab

"The thawab of deeds on Friday is twice as much. So avoid sins and do more good deeds to get more thawab." Prophet Muhammad (pbuh)

Complete the blanks

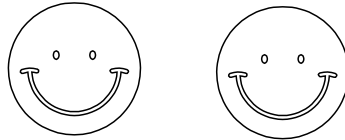
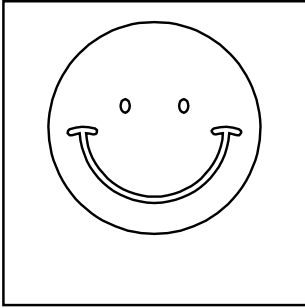

You get the thawab of 2 smiles



You get the thawab of .....p sadaqa



Get the thawab of cleaning..... rooms

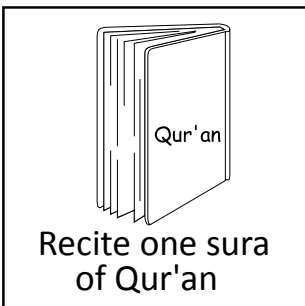

Get the thawab of reciting ..... suwer





# Friday Yawmul Jumua'

Circle the things recommended to do on Jumua'

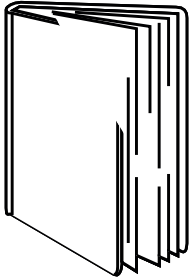

Learn about religion



Watch TV &/or play computer games

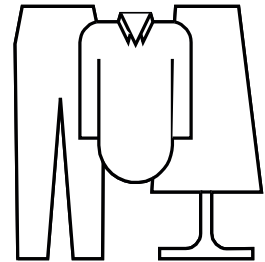

Wear neat clean clothes



Play games

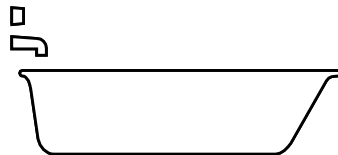

Have a long relaxing bath

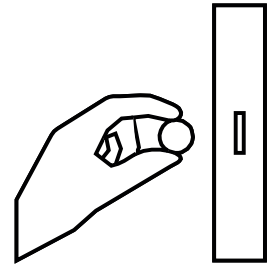

Give sadaqa

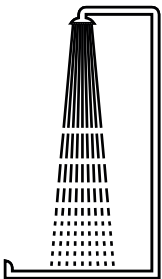

Do ghusl of Jumua'

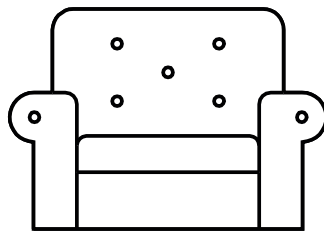

Relax



Recite salawat

Go shopping

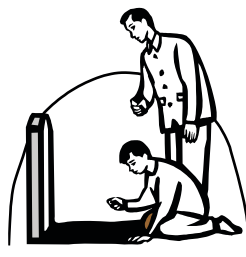

Visit graves of mu'mineen

Cut nails



# The month of Ramadhan

---

From the sermon of the Prophet (pbuh)

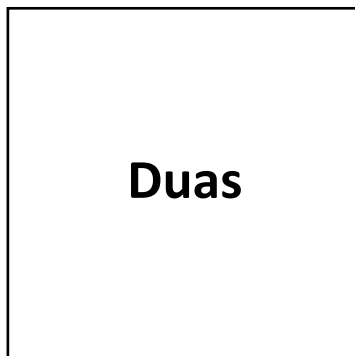
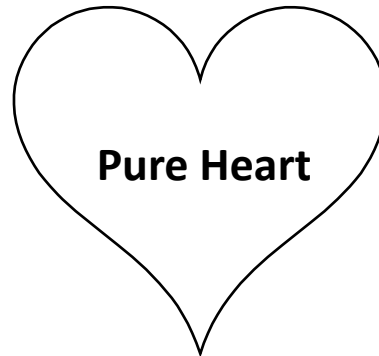
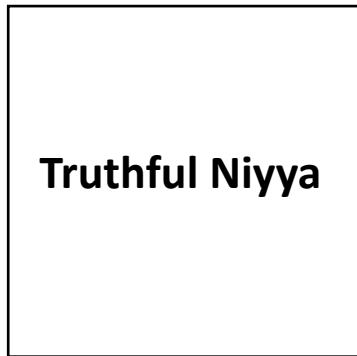

**Jahannam closed**

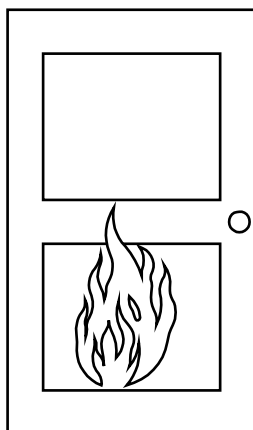

**Open Janna**

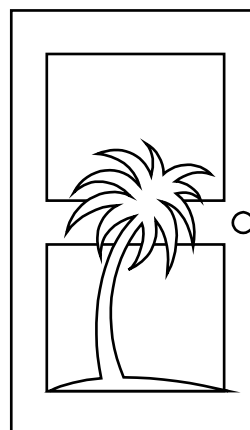

# Laylatul Qadr

Draw the web

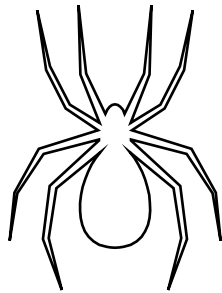

Sura Al-Ankabut

Colour in the smoke  
(dukhan)

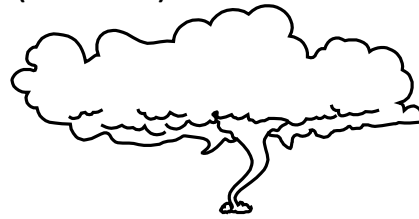

Sura Ad-Dukhan

Write 'R' for the Romans  
in the circle



Suratur Room

Who wrote the Duas  
in Sahifa As-Sajjadiyya?

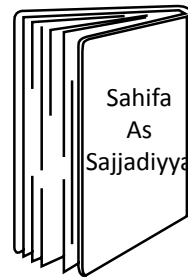

Dua Makarimul Akhlaq

What will you do  
Tawba for?

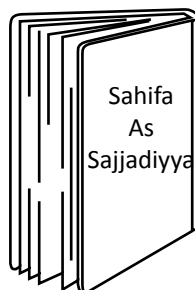

Dua e Tawba



# Friday Yawmul Jumua'

## Conditions for Friday Salaat

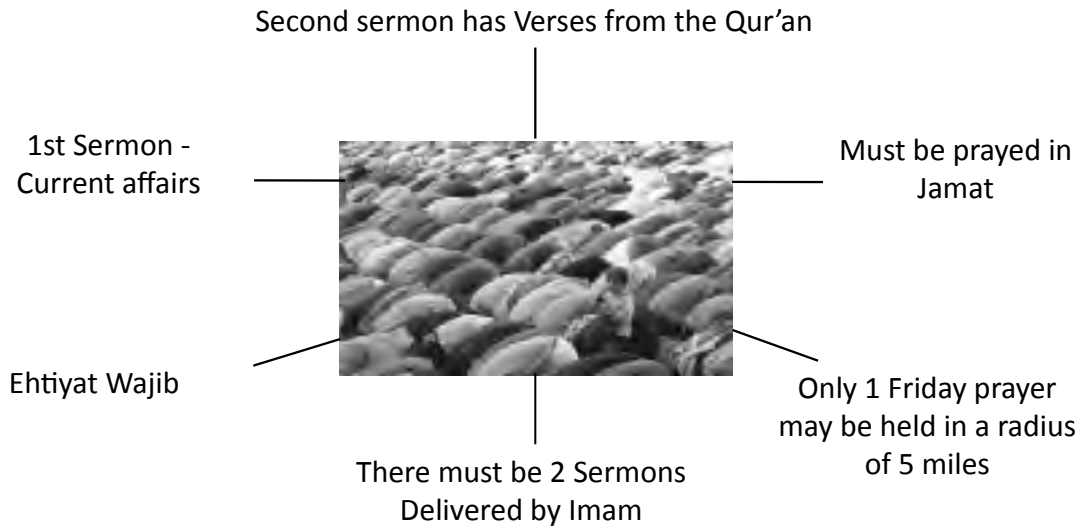

## Method of praying Friday Salaat

**Activity:** Zahid would like to pray salaat Juma. Can you please help him by putting the correct actions below in the right order.

TASHAHUD	2 <sup>nd</sup> RUKU	1 <sup>st</sup> set of SAJDAH
1 <sup>st</sup> QUNOOT	SALAAM	2 <sup>ND</sup> QUNOOT
1 <sup>st</sup> RUKU	2 <sup>nd</sup> set of SAJDAH	NIYAAT
1 <sup>st</sup> QIRA'AT	2 <sup>nd</sup> QIRA'AT	



# A friend is “God’s way of taking care of us...”

---

According to you what is a friend?  
We have given you one answer fill in the rest.

A friend is a person with whom you dare to be yourself.

---

---

---

Below is a list of “how to choose a friend” choose the points you think are correct and most appropriate.

1. Choose friends that have similar thoughts as you.
2. Choose someone you can chill with.
3. Choose a powerful friend who can fight all my battles in school.
4. Choose someone who has the same family values as you.
5. Choose someone who lives near your home.
6. Don’t be silly, you don’t choose friends you just hang around with people.
7. Choose someone who is popular so that you can share his name and fame.
8. Choose someone you can count on.
9. Choose someone who reminds you of God.
10. Choose someone who dresses and looks cool.
11. Choose someone who has lots of pocket money to share with you.



# Muharram Word Search

---

S F T H H U K Z U H A Y R  
S H A M U H A R R A M J O  
F A J A R M B M U S L I M  
S Y L S R A S O O L A L I  
A F T I Z H U S E I N M P  
K E R B A L A Y Q A S I M  
I P E O P K A B A O S T A  
N H O J H A B I B I A L L  
A C V B N B A A T N B O A  
H I L W A I T E R K B V M  
M O T H A T B A N I A Z A  
E W A T E R B A S K E T L  
D W I N R E H G S A I L A

Find the following words and circle them

WAHAB

MUSLIM

KERBALA

ZUHAYR

WATER

HABIB

SAKINA

HURR

ZAINAB

ALIASHAR

JOHN

ALIAKBAR

ABBAS

HUSEIN

QASIM

WATER

MUHARRAM

FAJAR



# New Year Resolution

There are different types of resolutions, some of them are mentioned below. Write down your own resolutions under each heading and complete the table below.



Resolution concerning my	My resolution	How will I achieve it
Spiritual		
Physical		
Community		
Family		
Education		



# The Day of Jumua'

---

Things to do on the day of Jumua'

1. Recite Suratul Jumua'

2.

3.

4.

5.

6.

7.

8.





# Places of Ziyara

---

Match the places with the correct name



**Saudi Arabia**  
Madina – Jannatul Baqee



**Iraq – Samarra**  
Imam Ali An Naqi (pbuh)  
Imam Hasan Al Askery (pbuh)



**Saudi Arabia**  
Makka – The Ka'ba



**Iran - Mashhad**  
Imam Ali Ridha (pbuh)



**Israel - Jerusalem**  
Masjid Al Aqsa



**Iraq – Kadhmayn**  
Imam Musa Kadim (pbuh)  
Imam Muhammad At Taqi (pbuh)



**Iraq – Najaf**  
Imam Ali (pbuh)



**Saudi Arabia**  
Madina – Masjid un Nabi



**Iraq – Karbala**  
Imam Husayn (pbuh)



